



Nanostructured Organic Polymer and Hybrid Materials : From Ultrathin Films to Nanoparticles

Rigoberto C. Advincula

**Department of Chemistry
Department of Chemical Engineering**

University of Houston

Houston, TX 77204

E-mail: radvincula@uh.edu

www.nanostructure.uh.edu

www.chem.uh.edu



University of Houston

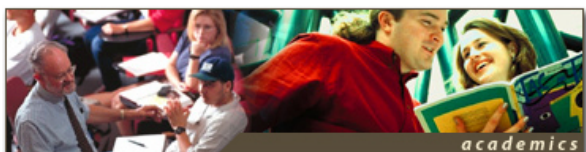

www.nsm.uh.edu, www.chem.uh.edu, www.egr.uh.edu

**Nanotechnology, Biotechnology, Materials Research, Molecular Design,
Polymers, Superconductivity**



Advincula Research Group

www.nanostructure.uh.edu



Ph.D. Students: Derek Patton, Tim Fulghum, Suxiang Deng, Prasad Taranekar, Yu Shin Park, Jin Young Park, Chengyu Huang, Ted Limpoco, Guoqian Jiang, Imee Martinez, Rebecca Tsai, Chaitanya Danda
Past: Chuanjun Xia, Mi-kyoung Park, Xiaowu Fan, Jason Locklin
Undergraduates: Mansour Abdulbaki, Jamie Chen, Gabriel Clyde, **Past:** Risheng Xu, Rusty Rogers, Pemieson Diep
Post-Docs and Research Staff: Dr. Akira Baba, Dr. Miko Millan
Past: Dr. Seiji Inaoka, Dr. Ji Ho Youk, Dr. Shuangxi Wang, Dr. Qing-Ye Zhou, Dr. Kenji Onishi, Dr. Miko Millan
Visiting: Paralee, Hiyoshi, Kawamura, Xinheng **Past:** Dr. Shinbo, **Others:** REU, Undergraduates, SEED, Foreign



Introduction

- **Outline:**
- Introduction
- Projects
- Recent Studies and Results
- Conclusions

Acknowledgment

Advincula Research Group

Collaborations:

- Zhenan Bao (Stanford)
- Wolfgang Knoll (MPI-P)
- Futao Kaneko (Niigata University)
- Hiroaki Usui (TUAT)
- Jimmy Mays (UT/ORNL)
- Norio Tsubokawa (Niigata University)

Funding:

- NSF-CAREER
- Welch Foundation
- NSF Collaborative Research in Chemistry
- NSF Chemical Sensors Program
- Lintec Corp.
- Dow Corning Corp.
- Agilent Technologies



Nanotechnology

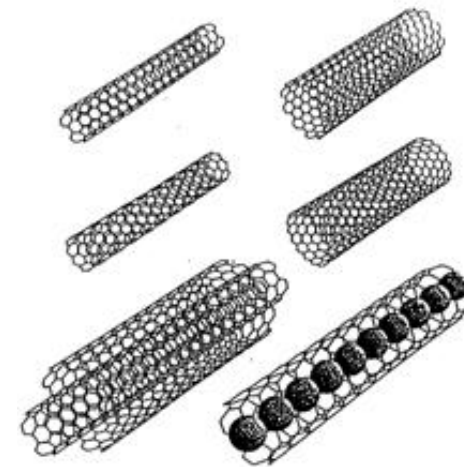
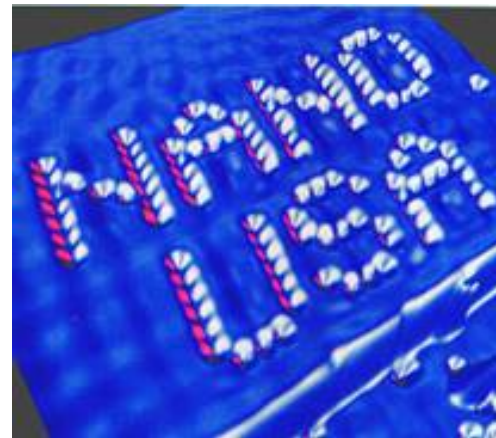
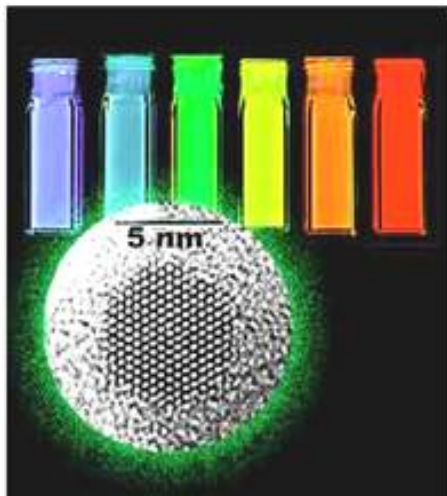

- self-assembly
- quantum effects
- molecular building blocks
- surface science

Nanostructured Material



Assemble from
Nano- building Blocks

- powder/aerosol compaction
- chemical synthesis

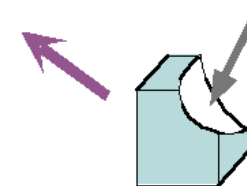

'Sculpt' from Bulk

- mechanical attrition (ball milling)
- lithography/etching...



Nanostructured Materials

Molecular and Macromolecular Design and Engineering at the nanoscale

- Design, synthesis, characterization
- application

- **Interfacial Phenomena**
- **Ultrathin Films**

- **Crystal Eng.**
- **Solid state**
- **High Vacuum**

- **Fundamental Science**
- **Technology**

Organic and Polymer Materials

- Surfactants, polymers, dendrimers, molecular organic crystals, films, micelles, nanoparticles
- Functional materials (optical, electrical, spectroscopic)
- Isotropic and "soft"

Inorganic Materials

- crystals, quantum dots, films, nanotubes, nanoparticles
- Functional materials (optical, electrical, spectroscopic)
- Anisotropic or long range order and "hard"

**Hybrid materials/
Nanocomposites**



Nanostructured Materials : Inorganic/Metals

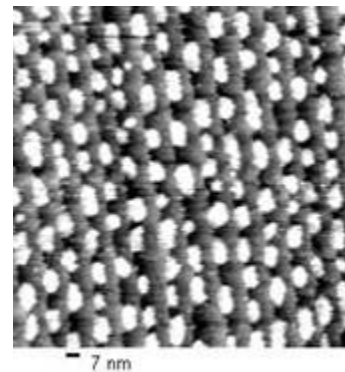
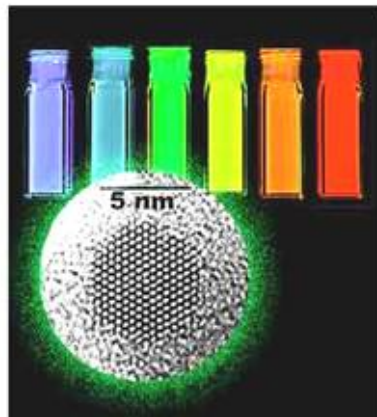
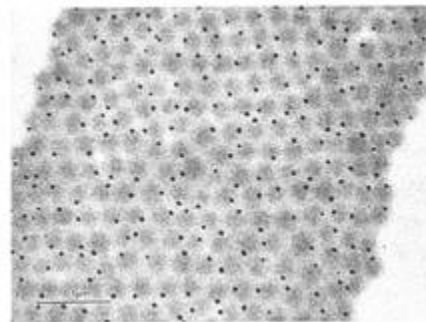
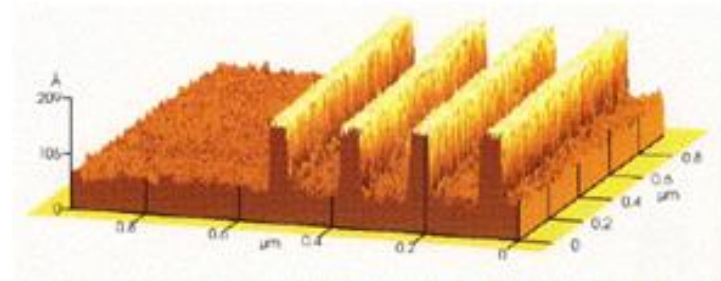
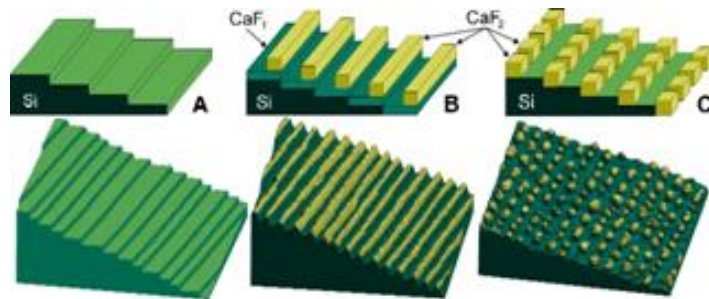

Inorganic

- **Nanoparticles** : quantum dots, nanocrystals, shape anisotropic nanoparticles
- Glasses and Ceramic particles
- **Ultrathin Films**: solid state, high vacuum, STM, doping, vacuum deposited.
- **Superlattice structures**: multilayer films, supramolecular structures, patterning



Nanostructured Materials : Carbon

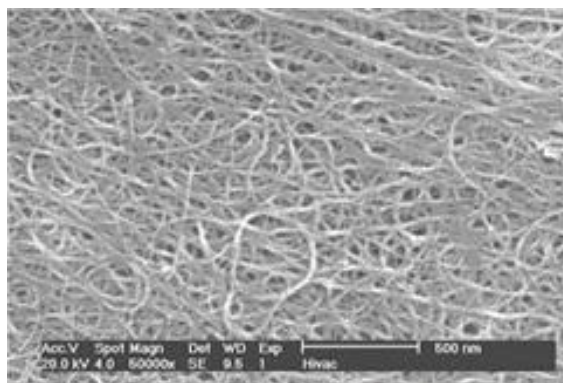

Carbon

- **Carbon-Based Nanomaterials** nanotubes (SWNT and MWNT), fullerenes, polyacene structures
- Electrical and magnetic effects
- Nanomechanical properties

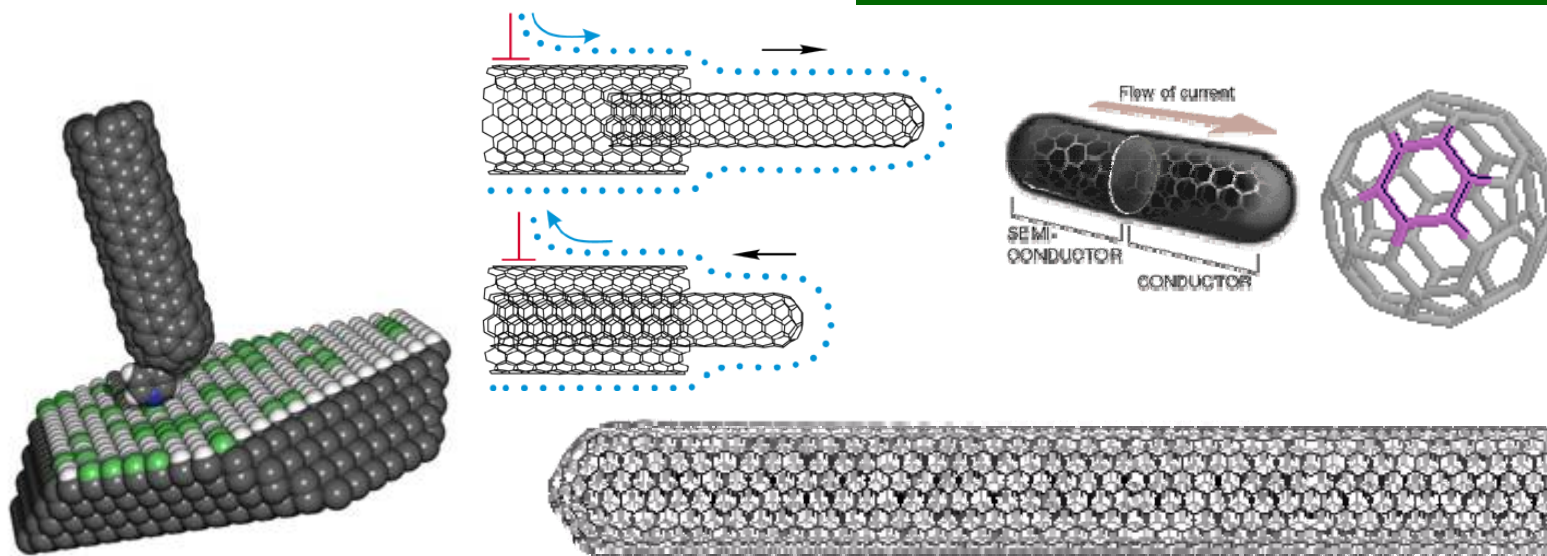



Nanostructured Materials: Organic

Organic

- **Organic Polymers :** homopolymers, block-copolymers, polyelectrolytes
- **Dendrimers and hyperbranched molecules** – functional macromolecules with controlled shape and dimension
- **Small Molecules:** organic crystals, dyes, oligomers, amphiphiles
- **Supramolecular Assemblies:** mesophases, supramolecular structures
- **Ultrathin Films:** Langmuir-Blodgett films, Self-assembled Monolayers (SAM), Layer-by-layer, epitaxy

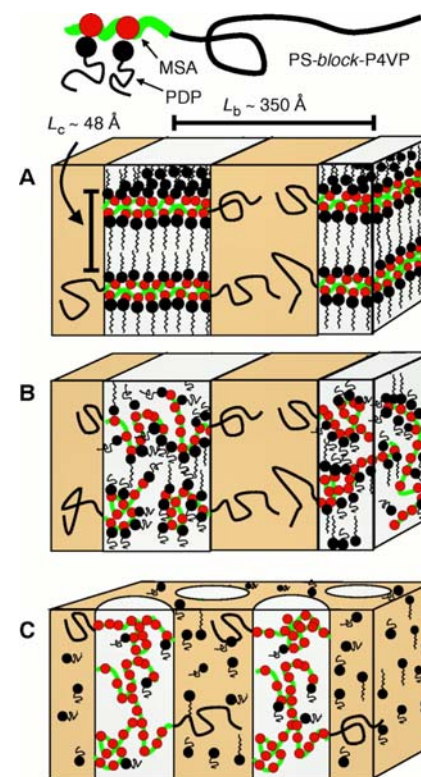
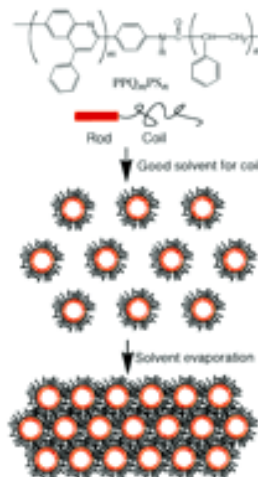
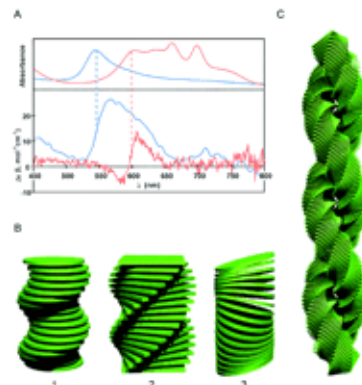
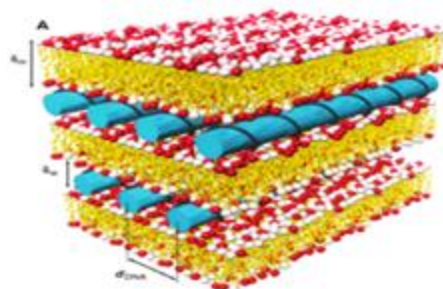
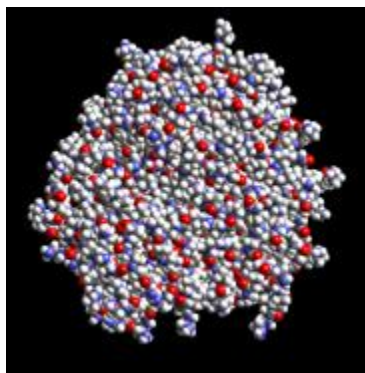



Outline of Projects

- ▶ **Project 1.** Electrodeposition and Patterning of Conjugated Polymers Using The Precursor Polymer Approach.
- ▶ **Project 2.** Nanostructured Ultrathin Films of Oligothiophenes and Dyes.
- ▶ **Project 3.** Living Anionic Surface Initiated Polymerization (LASIP) on Nanoparticles
- ▶ **Project 4.** Nanoparticle Synthesis Using Block Copolymer Micelles, Star Copolymers and Polyelectrolyte Complexes
- ▶ **Project 5.** Functional Dendrimers as Organic Nanoparticles
- ▶ **Project 6.** Hybrid Nanoparticle-Dendron Materials: Energy Transfer Phenomena
- **Conclusions**



Project 1

Electrodeposition and Patterning of Conjugated Polymers Using the Precursor Polymer Approach.

NSF-CAREER: DMR 99-82010

Agilent Technologies



Introduction ... Conjugated Polymers

Conjugated (Conductive) Polyheterocycles

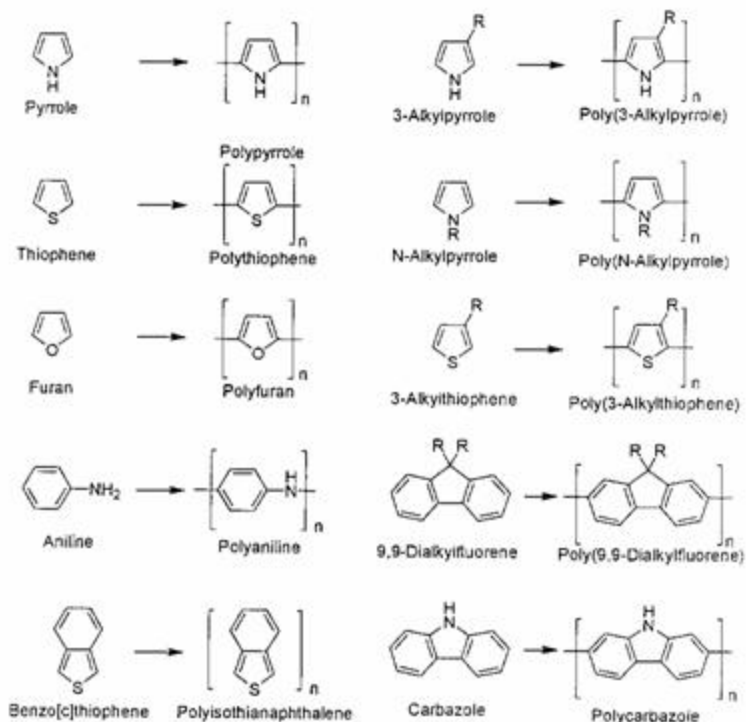

- **Electro-optically active**
- **Non-linear Optical Materials**
- **Electrically-conducting Polymers**
- **Luminescent Polymers**
- **Lasing Polymers**

- **intractable and insoluble**
- **defects and impurities**
- **mobility and band-gap conditions**
- **processability**
- **patterning**



Introduction ... Display Devices

Organic Light Emitting Diode (OLED) devices

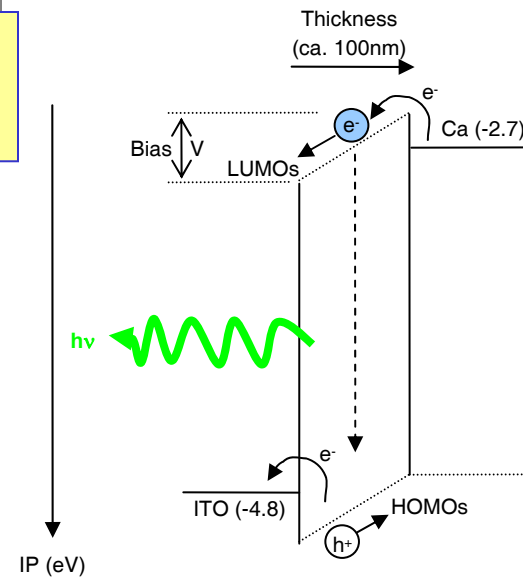
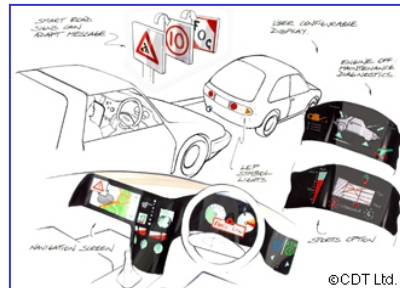
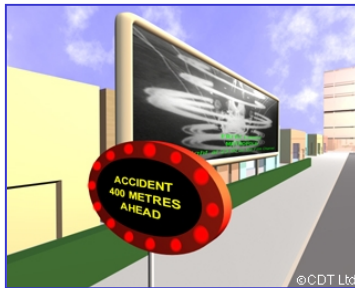
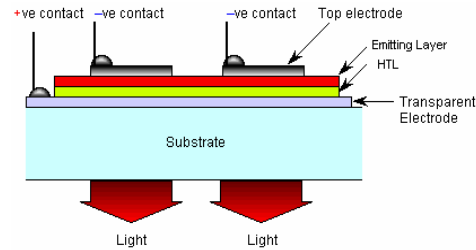

- Asymmetric structure (diode)
- Electrons are injected in LUMOs
- Holes are injected in HOMOs
- Charge hopping leads to recombination:
 $e^- + h^+ \rightarrow hv$
- Maximum estimated external efficiency < 5%





Challenges in PLED Patterning

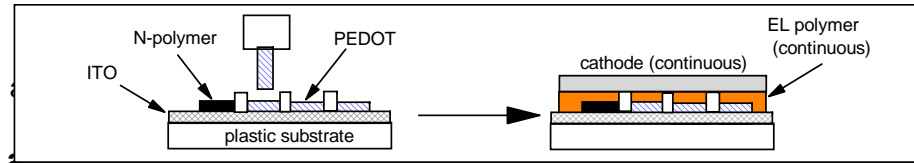

Print the image with a conducting (PEDOT) and insulating (N) polymers. Coat with continuous layer of EL polymer.

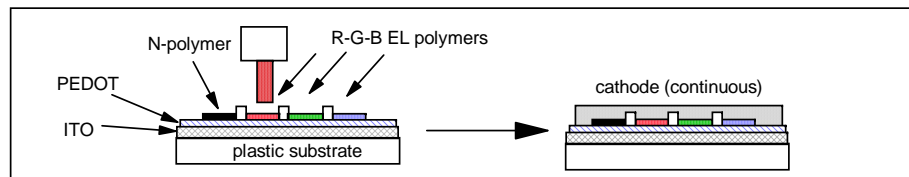

Print the image with emitting (EL) and insulating (N) polymers.

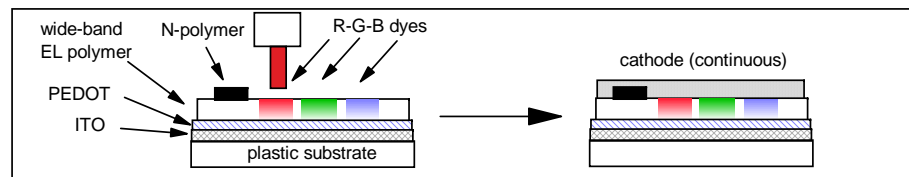

Print the image with dyes which diffuse inside a wide-band emitting polymer film.

Efficiency	Green ~20 lm/W @ 100 cd/m ² (2.6V) (>5% external efficiency) Excellent red, and good blue
Half-life	approximated at room temperature: red ~30,000 hr, green>10,000, blue~2,000 h.
Colors	Excellent saturation, very close to standard PAL limits.

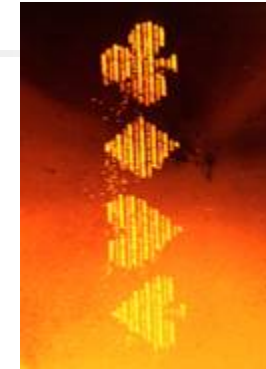

Full color active matrix display
CDT-Seiko Epson 1999

Patterning

- A- Shadow Masking.
- B- Filters
- C- Printing (inkjet)
- D- Microlithography
- E- Electropatterning
- F- Self-Assembly
- G- Nano-patterning ??



Patterning by Electrodeposition

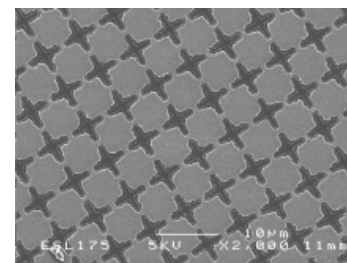
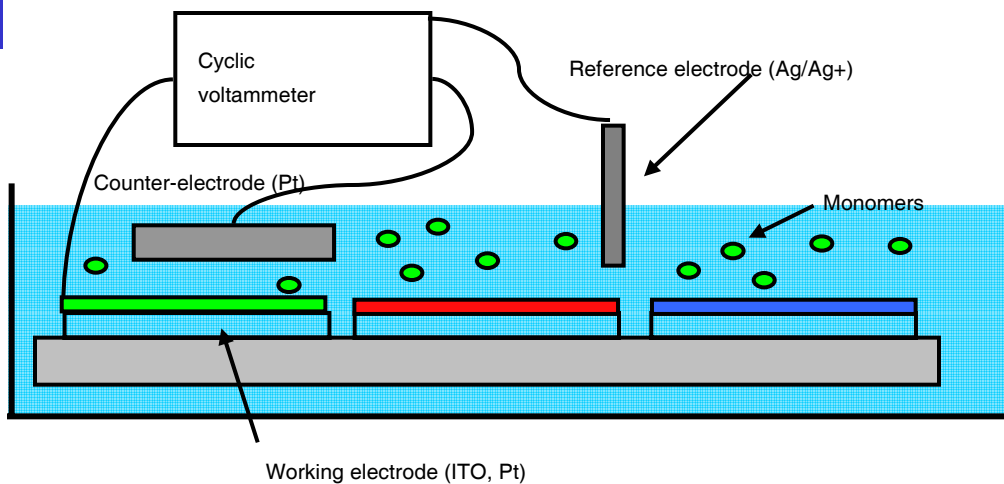

Possibilities for site- directed nanopatterning?

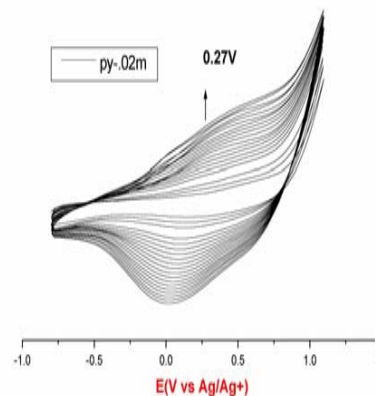
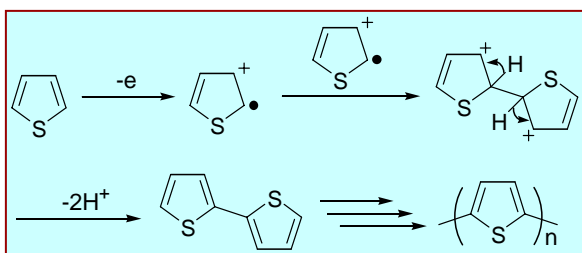
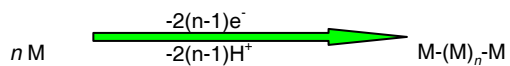

- *Thin Films*, R. Advincula, C. Xia, S. Inaoka, D. Roitman "Ultrathin Films of Conjugated Polymers on Conducting Surfaces" M. Soriaga, Editor.



Problems with film morphology using traditional monomers

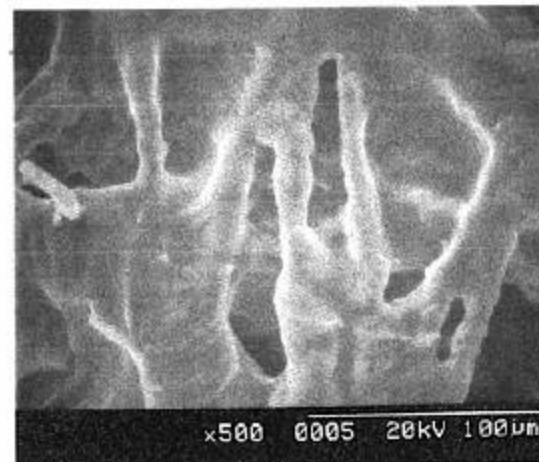
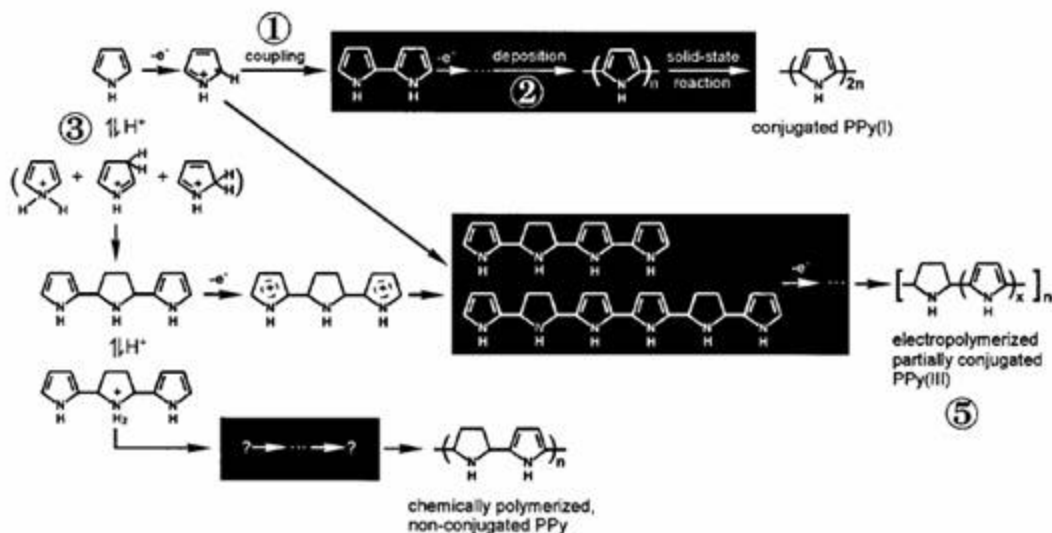

- ill-defined mechanism of film growth
- chemical defects
- rapid precipitation from solution

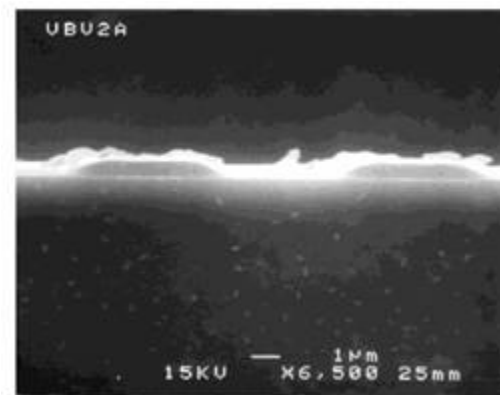
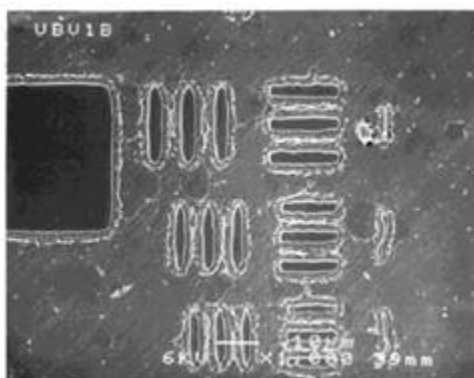



Precursor Polymers: Electropolymerization approaches to Functional Ultrathin Films and Patterning of Conjugated Polymers

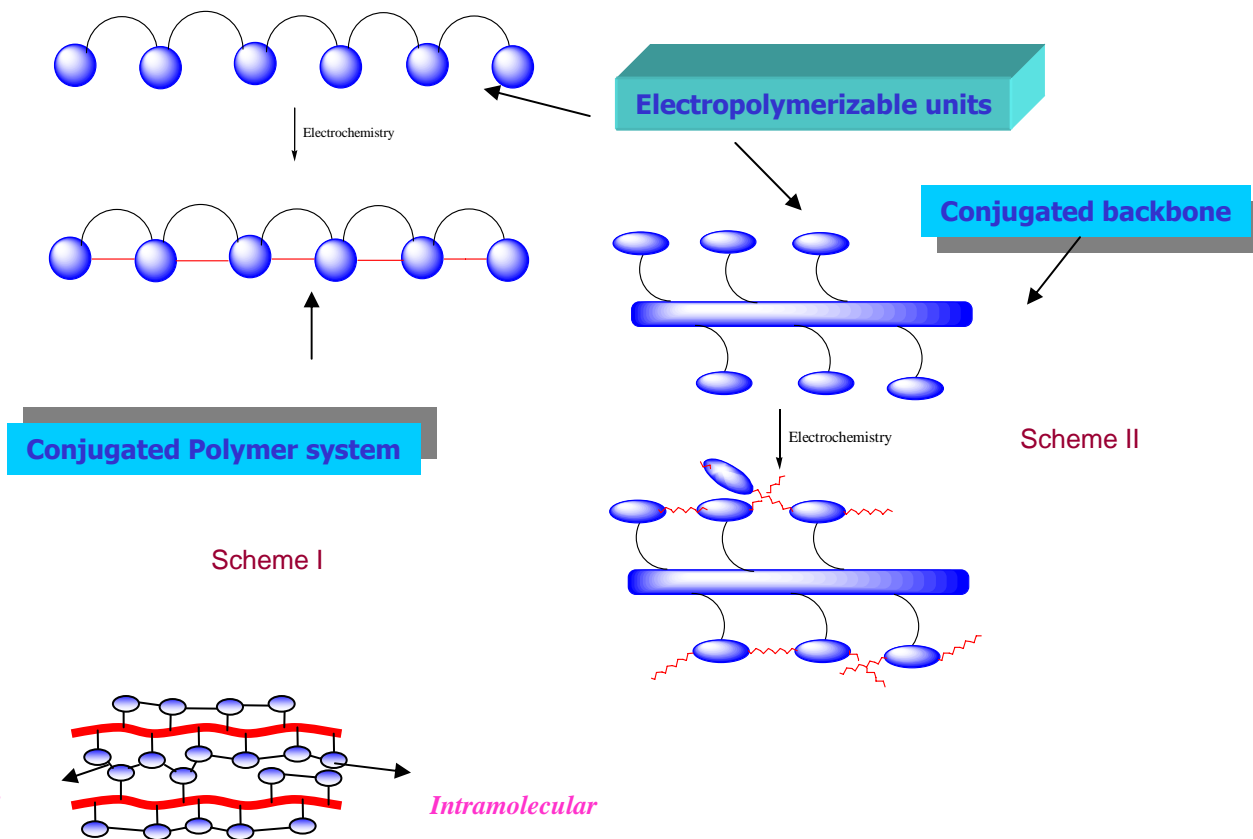

- Baba, A.; Onishi, K.; Knoll, W.; Advincula, R.* *J. Phys. Chem. B.* **2004**, *108*, 18949-18955.
- Xia, C.; Advincula, R.*; Baba, A.; Knoll, W.* *Chem. Mater.* **2004**, *16*, 2852-2856.
- Deng, S.; Advincula, R.* *Chem. Mater.* **2002**, *14*, 4073-4080.
- Taranekekar, P.; Fan, X.; Advincula, R.* *Langmuir* **2002**, *18*, 7943-7952.



Project 1a. Surface Grafting of Polyfluorenes onto SAM Modified Conducting Substrates by Electrochemistry

Polyfluorenes

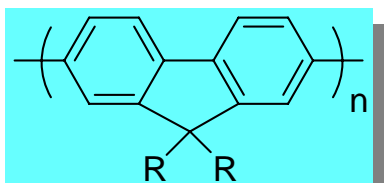

- **Blue emitter**- PLED Devices
- **Color-tuning** via copolymerization
- Synthesis by **Suzuki** or Yamamoto Coupling
- **Aggregation behavior** as films
- **Polarized Emission** in oriented films

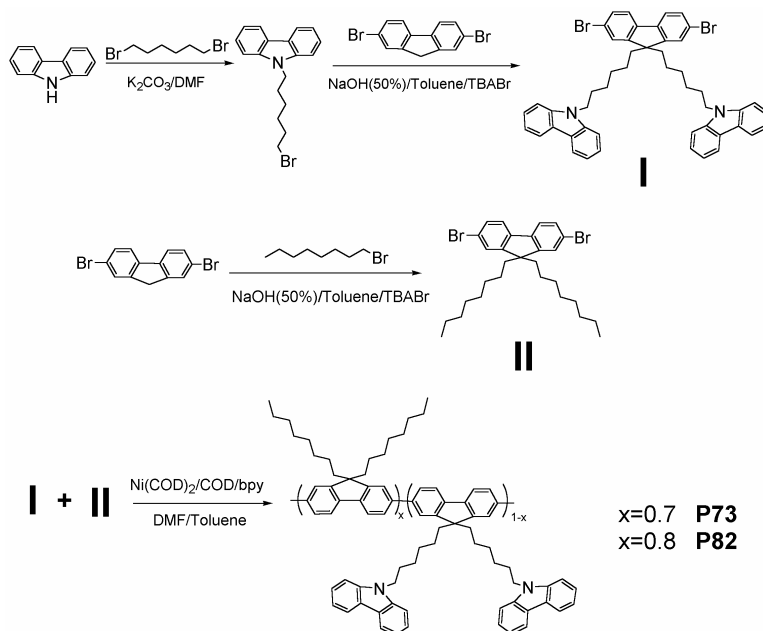
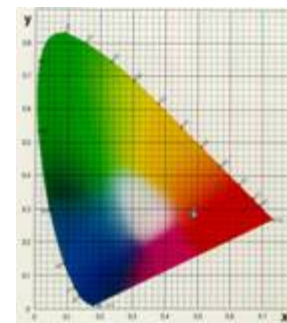

Scheme 3 Schematic Illustration of Crosslinking by Electrochemistry

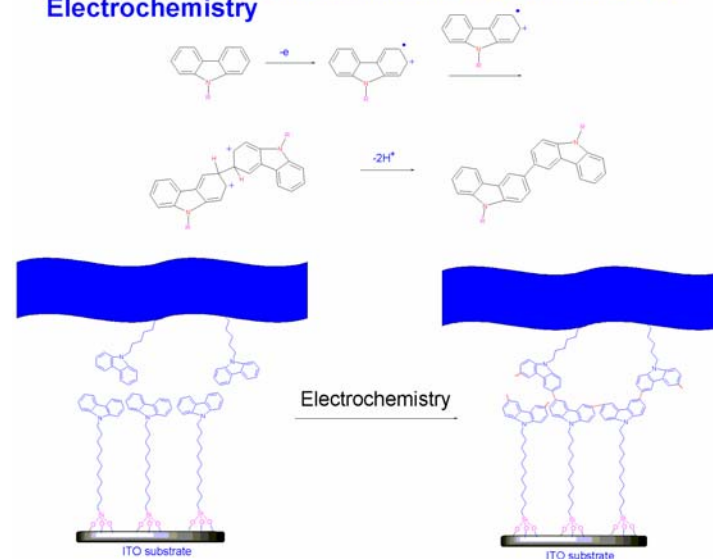



Electropolymerization from Films or Solutions

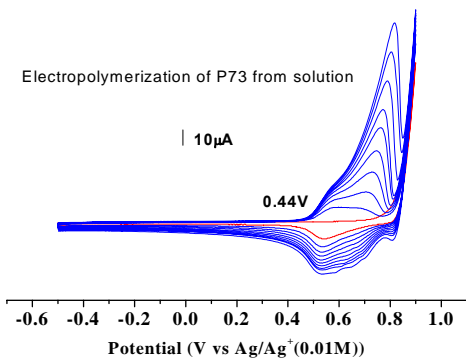
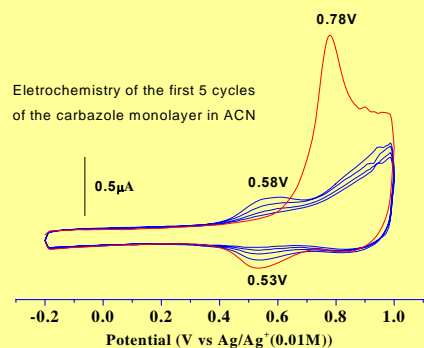

Electropolymerization

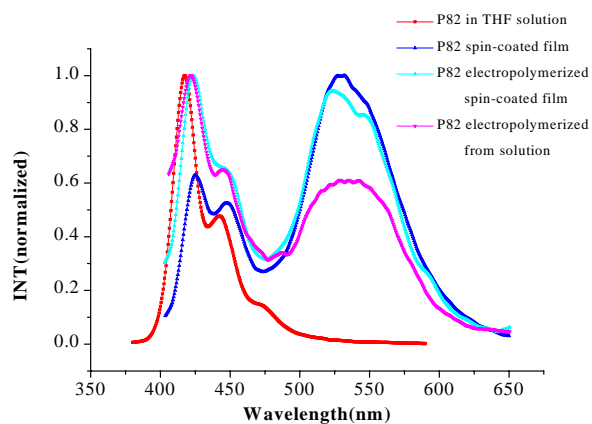

Photoluminescence of P82

SAM modified ITO

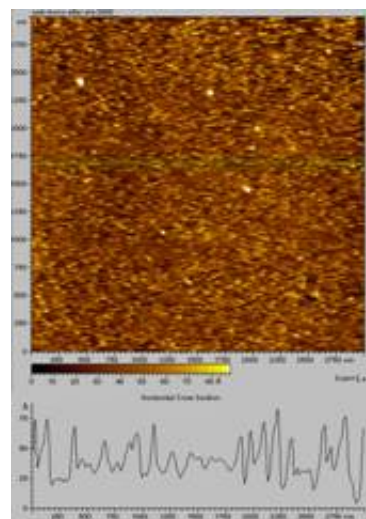

P73 spin-coated film after electropolymerization

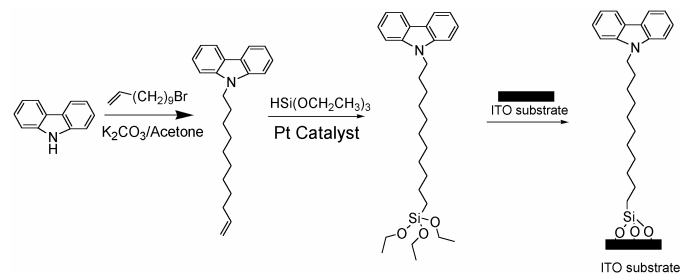
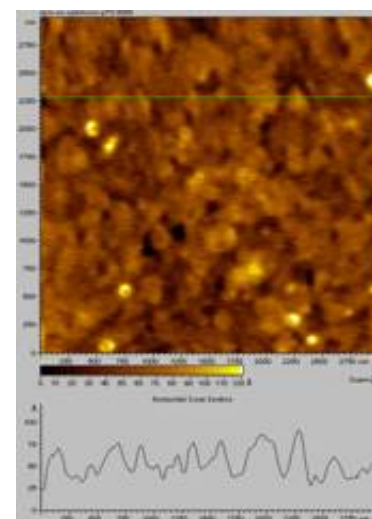



Project 1 b. Polysiloxane Modified Polythiophene Precursors

Siloxane polymers

- low surface tension
- high gas permeability
- thermal stability
- water repellence
- high dielectric constant

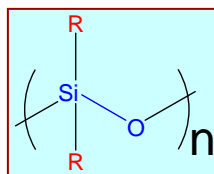
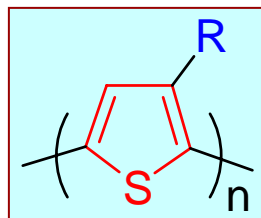

Polythiophene

- Important conducting polymer
- Color tunable light-emitting polymer
- Superconducting at low temperature
- High mobilities
- Non-linear optical polymer

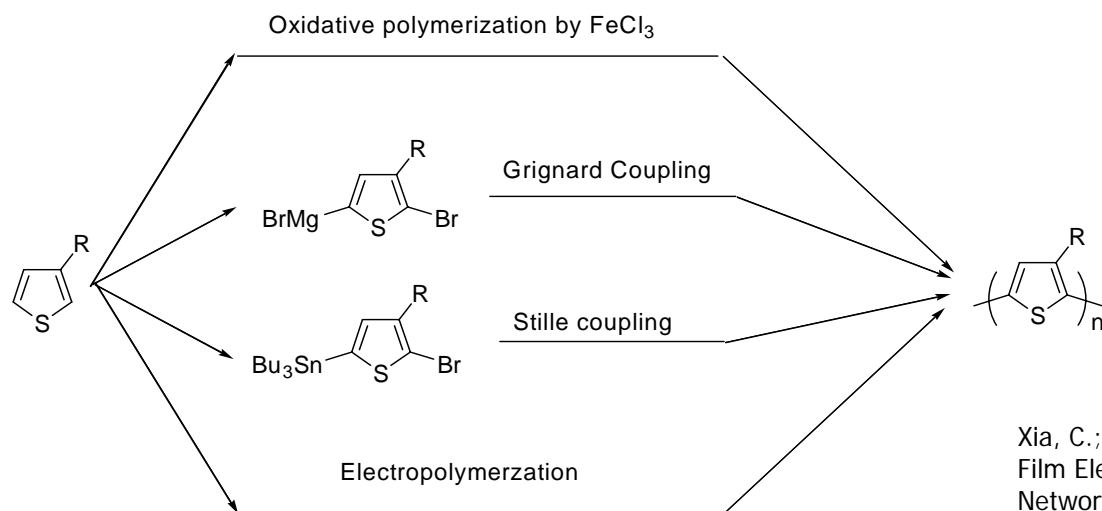

Xia, C.; Fan, X.; Park, M-K.; Advincula, R. "Ultrathin Film Electrodeposition of Polythiophene Conjugated Networks through a Polymer Precursor Route", *Langmuir* **2001** 17(25), 7893-7898.



Nanostructured electrodeposited layer-by-layer films observed by Surface Plasmon Spectroscopy (SPS)

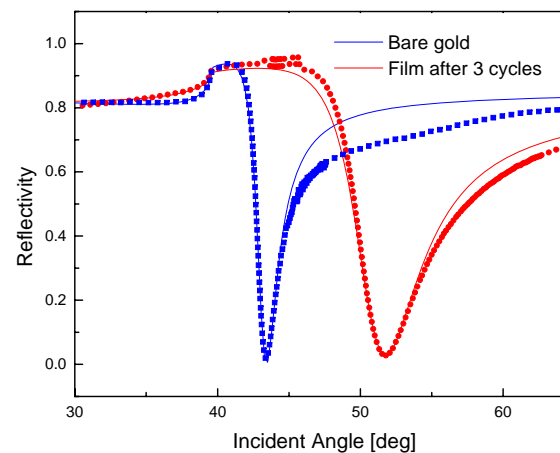
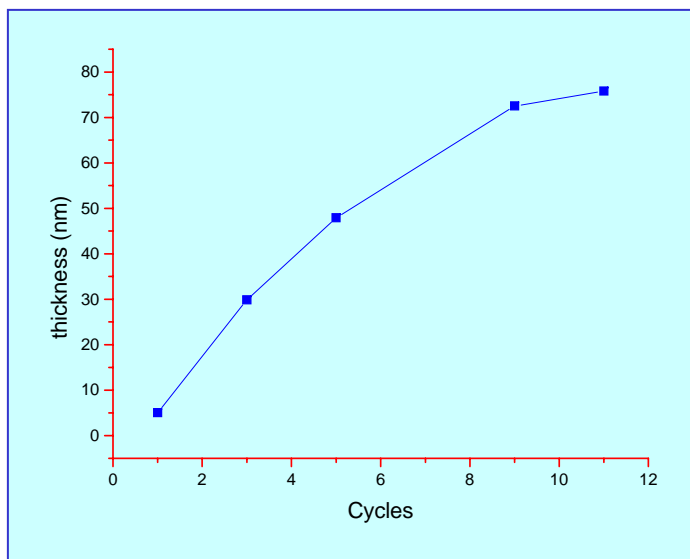

- Attenuated total reflection (ATR) setup in a *Kretschmann* configuration, optics is away from the sample and subphase
- Evanescent wave optical technique
- Quantitative treatment by the Fresnel theory
- PSP excitation observed in reflectivity-angular scan

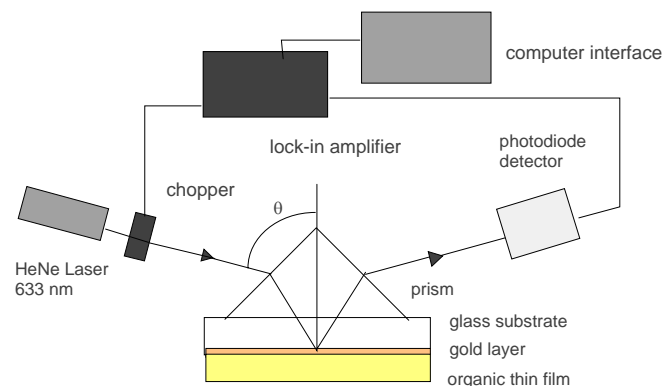

Knoll, W. *Annu. Rev. Phys. Chem.* **1998**, 49, 569-638.



Morphology Control from Copolymerization of Monomers and Precursor polymers

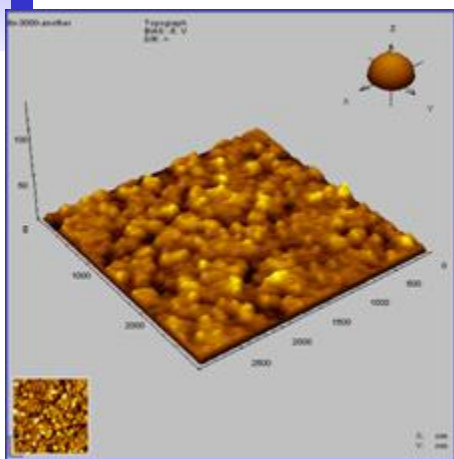

AFM image of the Indium-tin oxide (ITO) substrate

Deposited from a solution containing 0.09M thiophene and 0.01M precursor polymer.

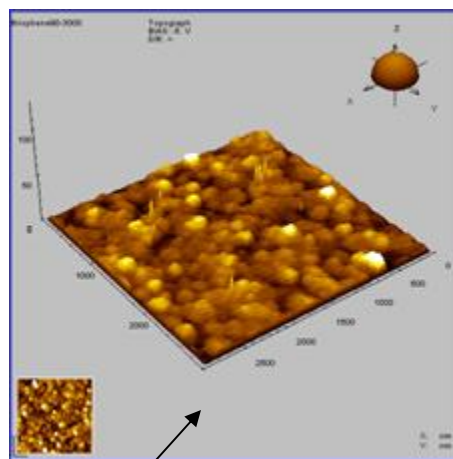

0.08M thiophene and 0.02M precursor polymer.

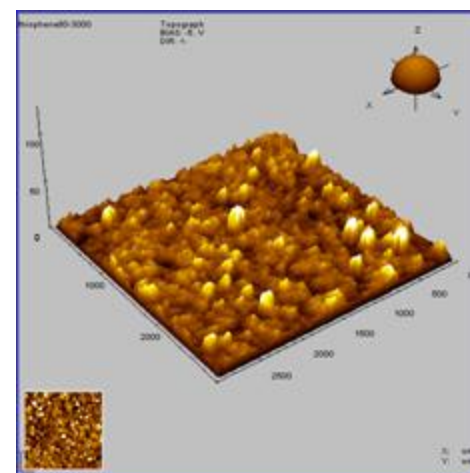

0.07M thiophene and 0.03M precursor polymer.

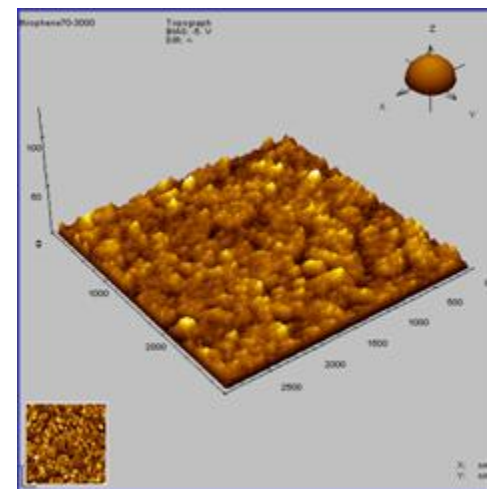

Morphology dependent on Monomer/Precursor polymer ratio.



Combined SPS-Electrochemical Set-up

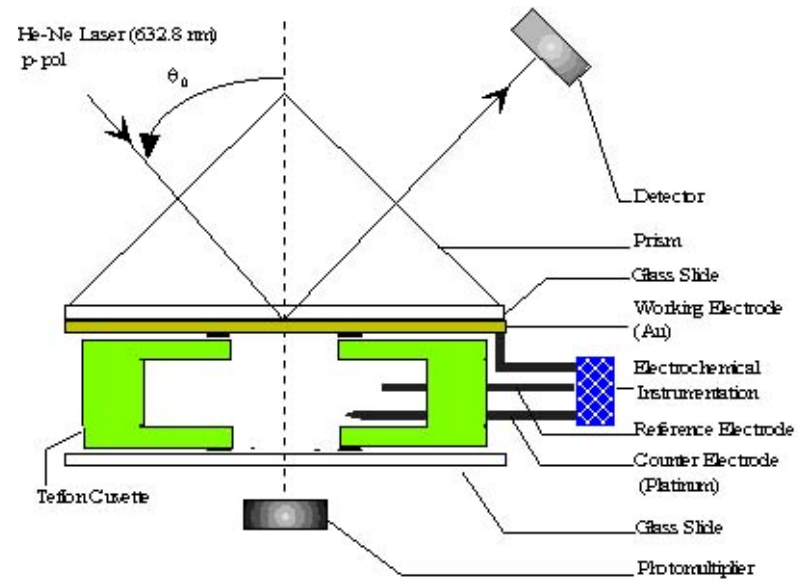
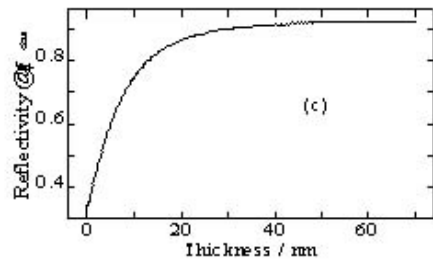
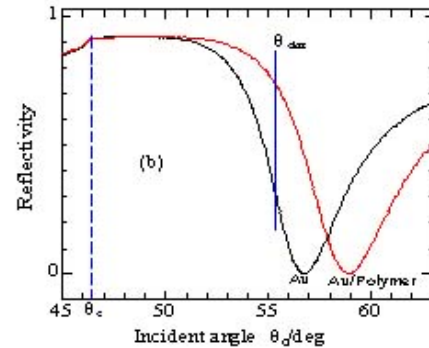
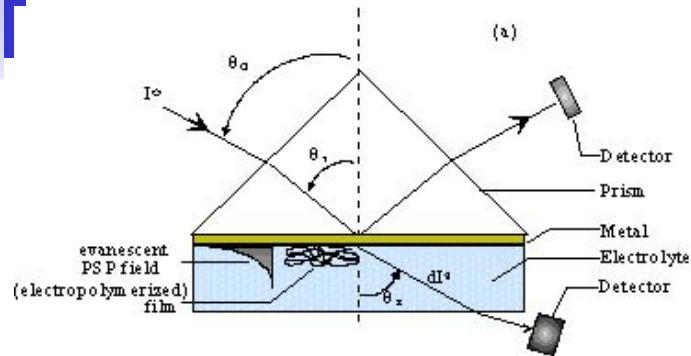

Combined SPS and Electrochemical Cell Set-up

Calculated reflectivity

Au(50nm)/electrolyte($\epsilon = \epsilon' + i\epsilon'' = 1.75 + i0$) interface

Au (50nm)/deposited film (10nm, $\epsilon = 2.25 + i0$)/electrolyte.

Kinetic information on the layer formation - monitoring the reflected intensity at a fixed angle, θ_{obs}

Calculated reflectivity change at a fixed angle θ_{obs} - function of thickness of deposited film on the Au substrate.



Cyclic redox Stability of Cross-linked Films

- Potential Ramp, SPS and SPFELS kinetic curves during electro-deposition of different ratios of monomers and precursor polymers in the methylene chloride containing 0.1 M TBAH up to 5 cycles.
- Reversibility of cycle different with composition
- Changes in internal morphology with doping and dedoping – also composition dependent

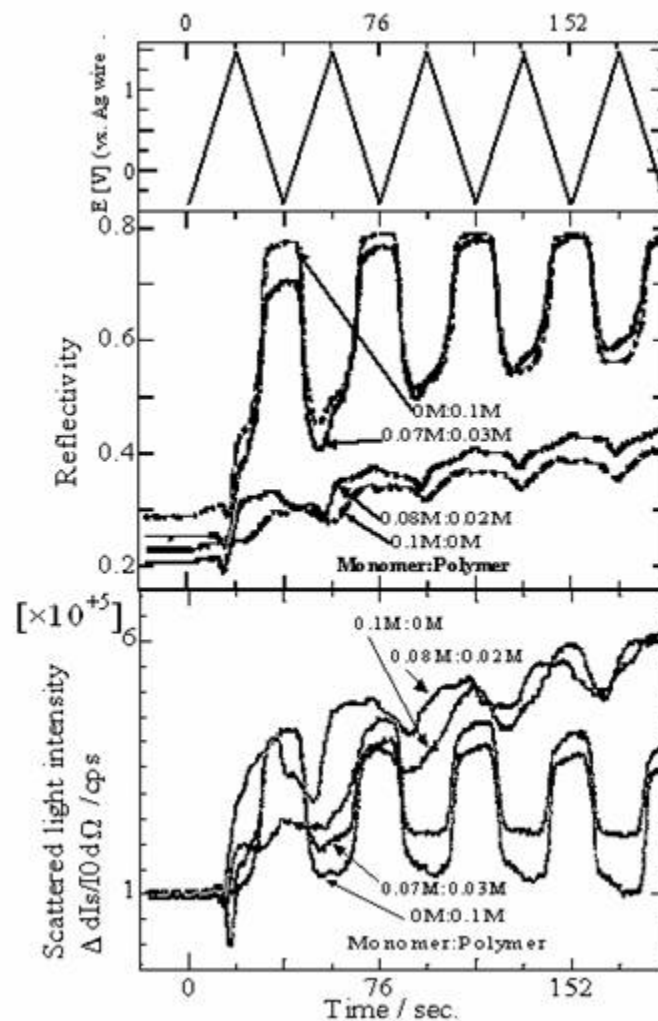
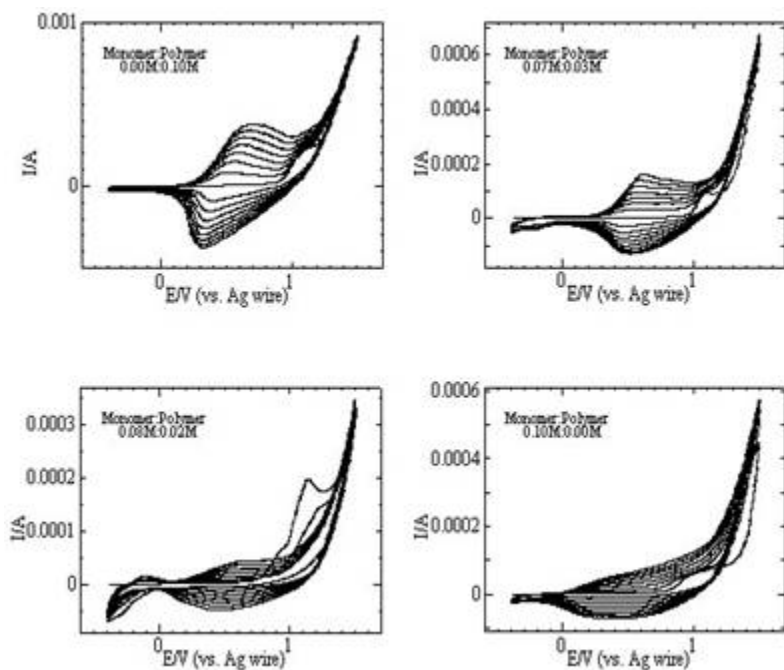



Synthesis of Polysiloxane modified polypyrroles

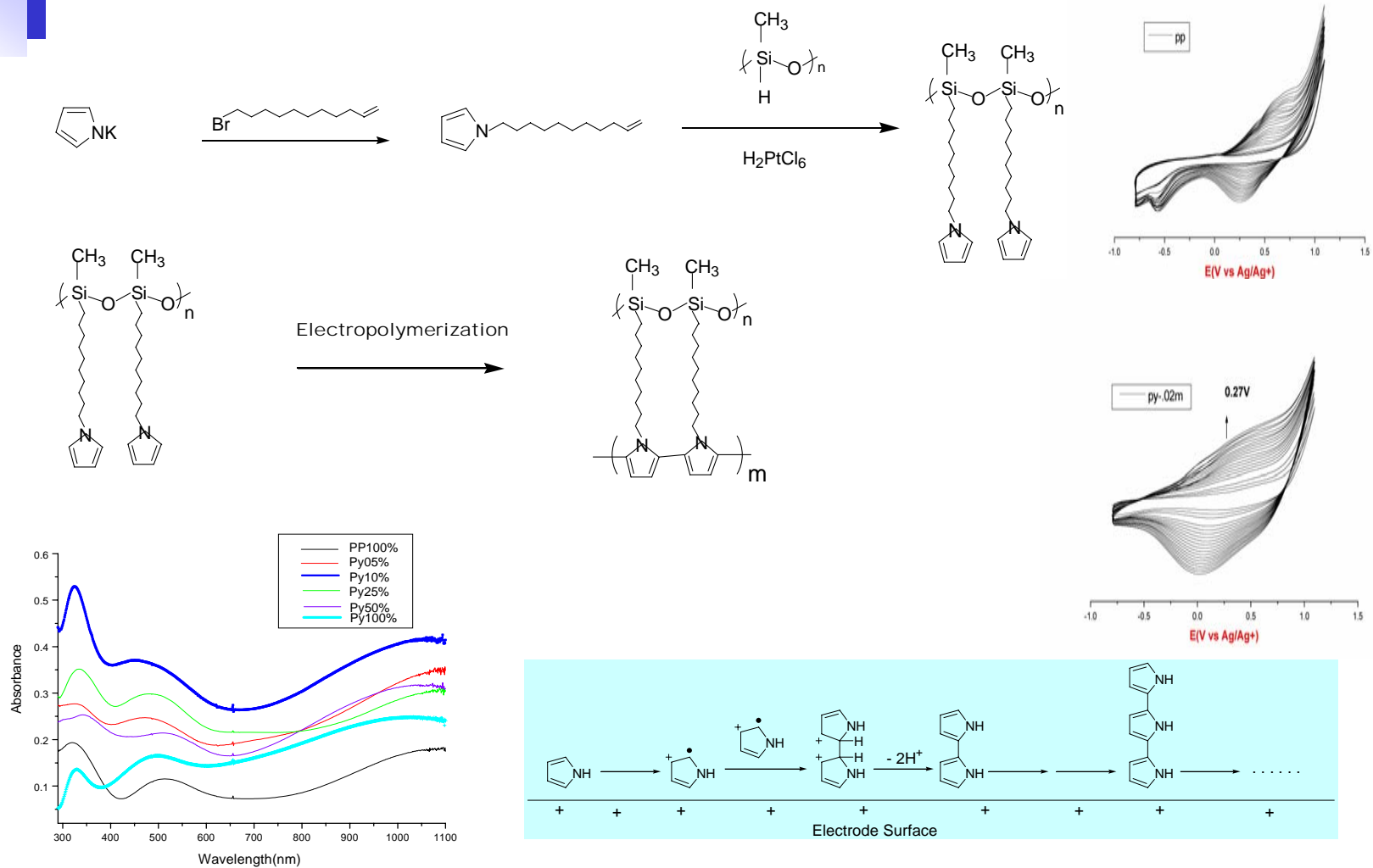

Taranekar, P.; Fan, X.; Advincula, R.* *Langmuir* **2002**, *18*, 7943-7952.



Project 1c. Polypyrrole Precursors: “Nanodots” on Polypyrrole films

Precursor Polypyrrole

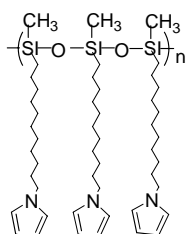

Electropolymerization of Precursor Polypyrrole

Electropolymerization

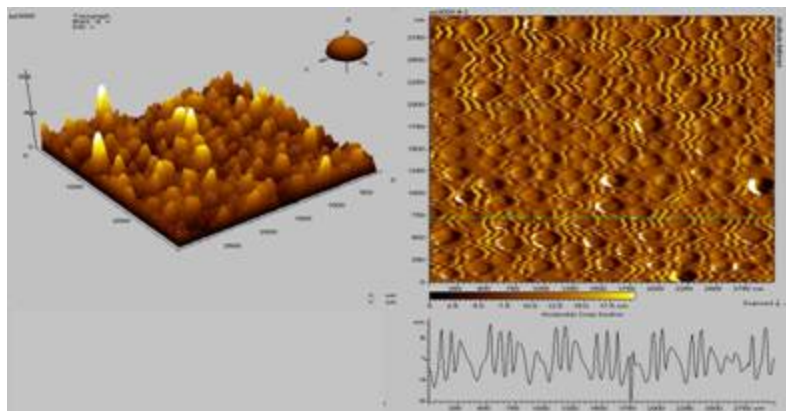
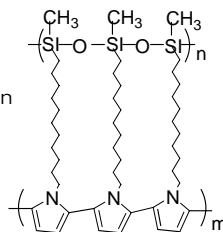

Nano-dots on Polypyrrole Film

SAM modified ITO

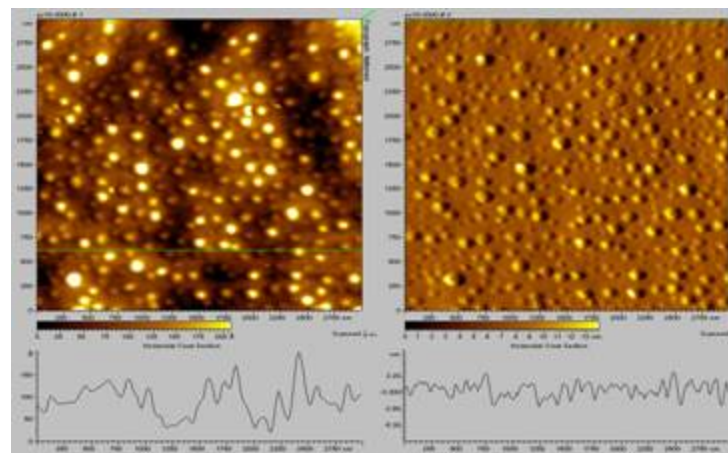

- **Designed synthesis**
- **Morphology studies.**
- **Electrochemistry**
- **Spectroscopy**
- **size of dots dependent on monomer: precursor polymer ratio.**



Project 1d. PMMA-Polypyrrole Precursor Ultrathin Films

Precursor Polypyrrole

Comparison of Morphology of Polypyrrole and Precursor

Higher optical quality

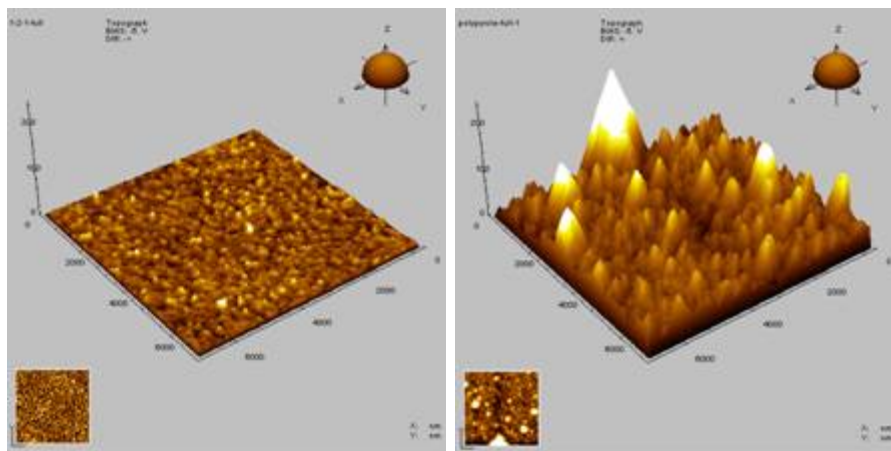

Electropolymerization

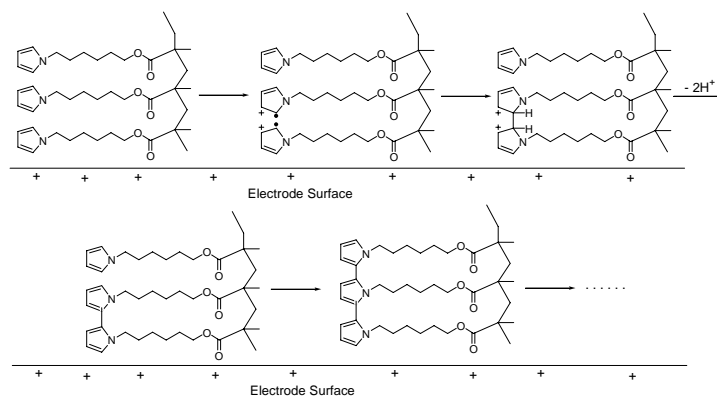
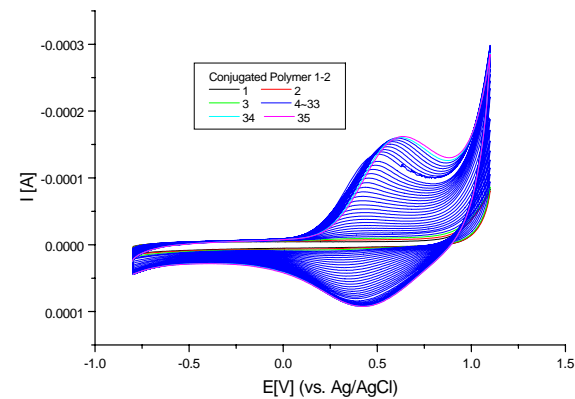

- Optical studies
- Electro-optical studies
- Applications



Project 1e. Polyvinylcarbazole (PVK) to polycarbazole

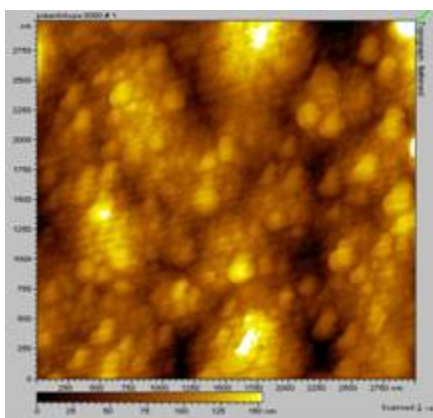
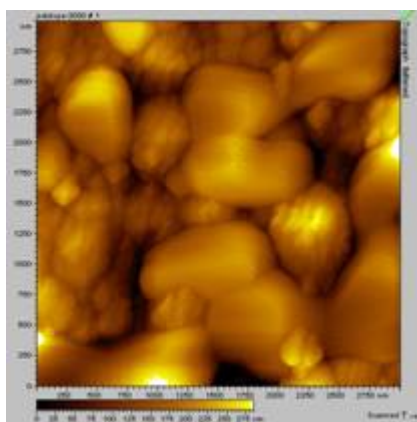
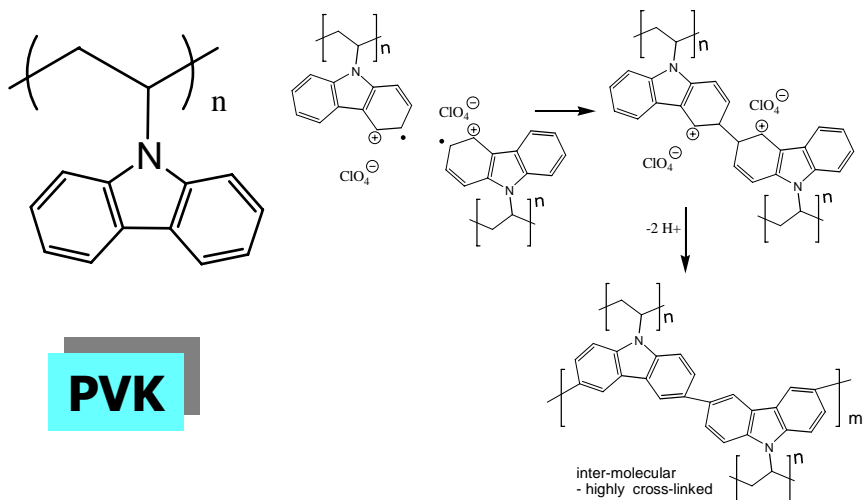

Film formation and cross-linking was found above 0.8 V by CV.

Two peaks of 0.6 - 1.2 V and above 1.2 V.

Potentiostatic or CV method

DC conductivity: Dielectric properties

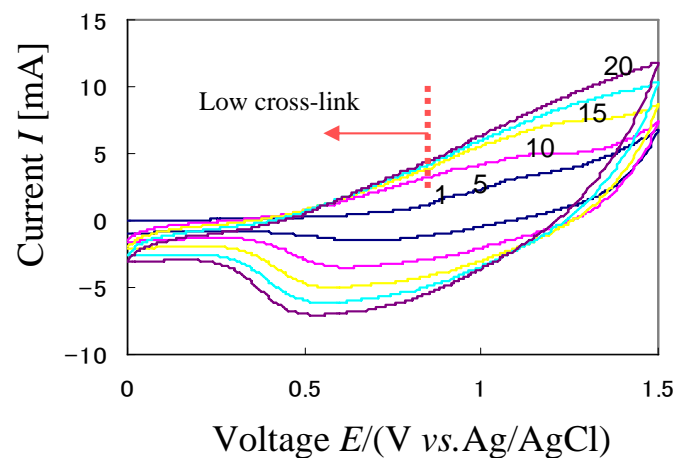



PVK and Polyfluorenes: Work-Function Tunable PLED Devices

PLED Performance changes with Doping of PVK Films: hole-transport

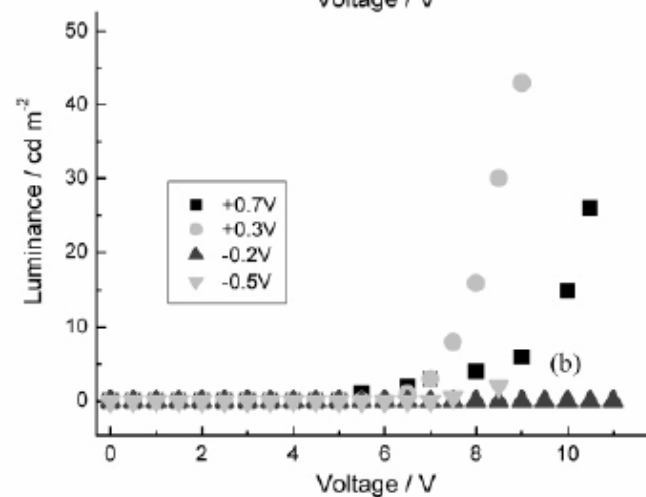
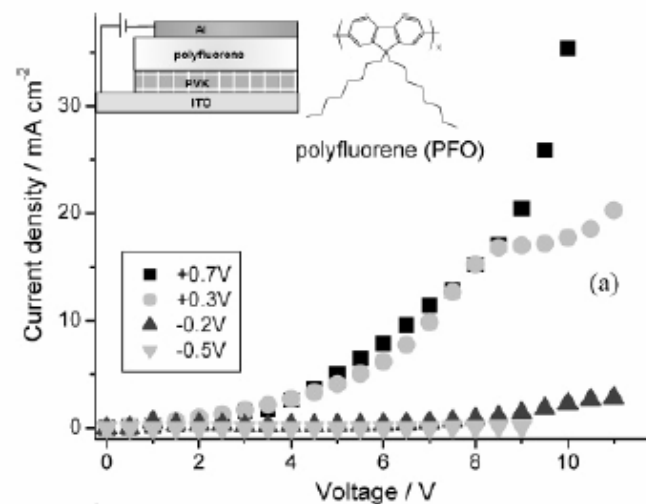
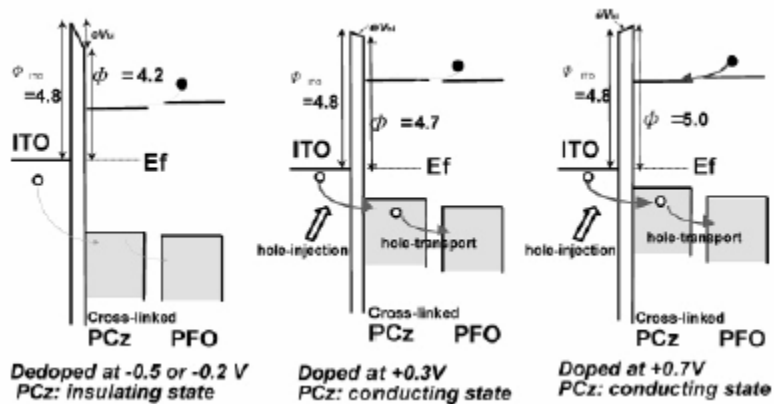
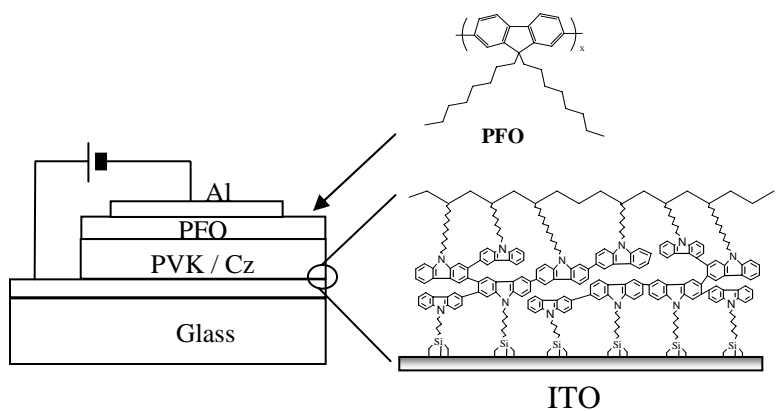



Micro-contact Printing of SAMs

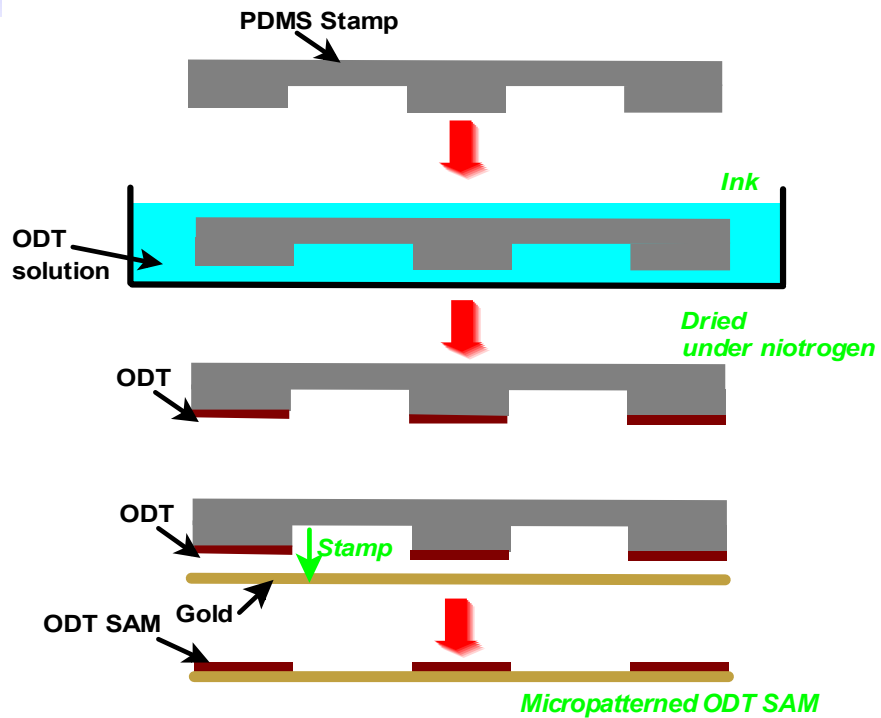

Schematic representation of microcontact printing

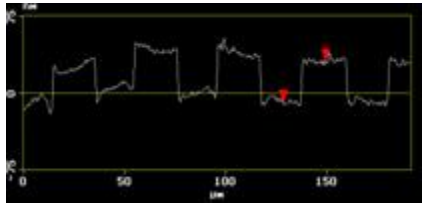
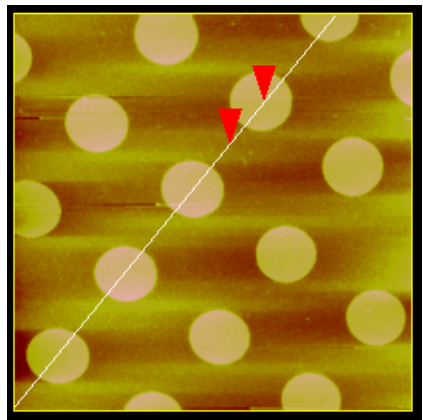



Patterning strategies: Micro-contact Printed Electrodeposition

Micro-contact printing of SAM monolayer

-selective deposition of precursor polymer both by potentiostatic and CV methods

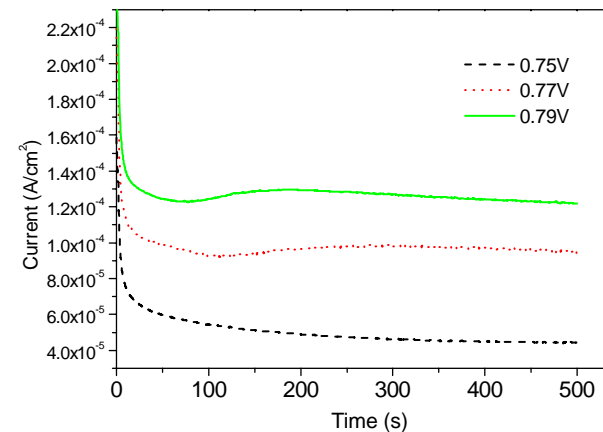
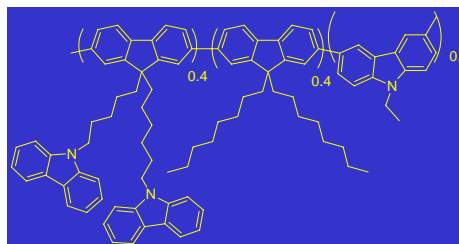
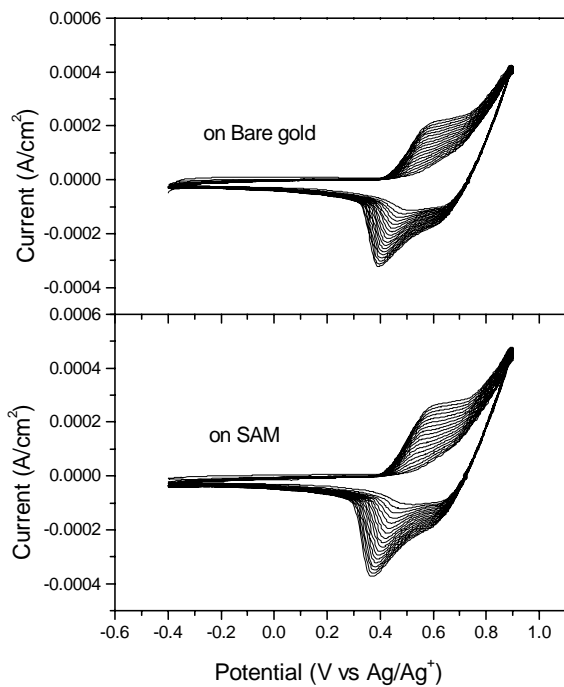

- Xia, C.; Advincula, R.*; Baba, A.; Knoll, W.* *Chem. Mater.* **2004**, *16*, 2852-2856.



Electrochemical Nanolithography of PVK? Yes

- Electropolymerization and crosslinking of PVK
- Substrate patterning independent of template
- Robust patterns with height profile

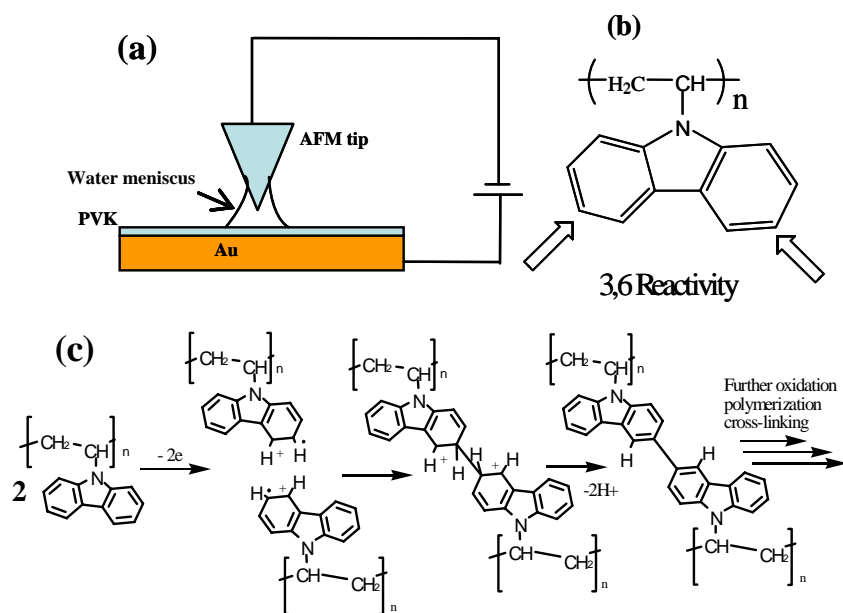

Valiyaveetil, S.; Advincula, R.; Subbiah
Advanced Materials **2005** in press.

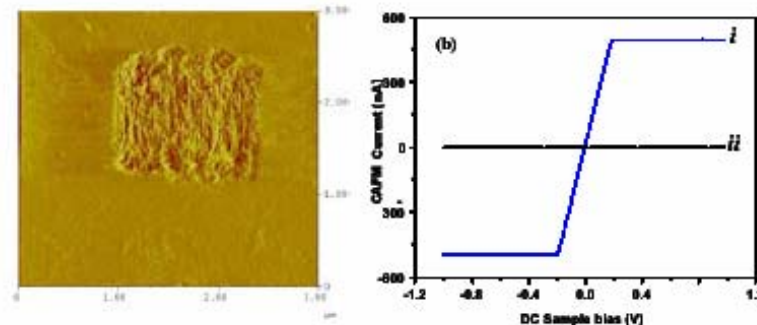
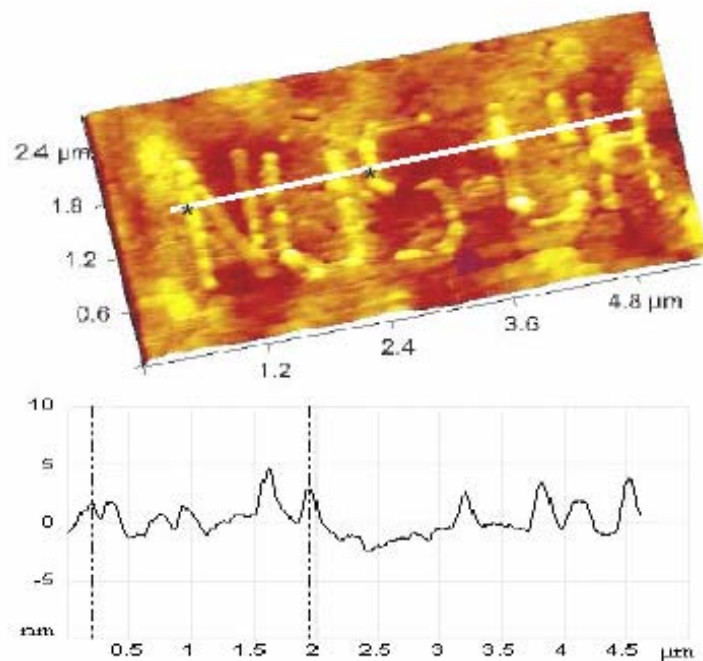



Control of Nanopatterning Features

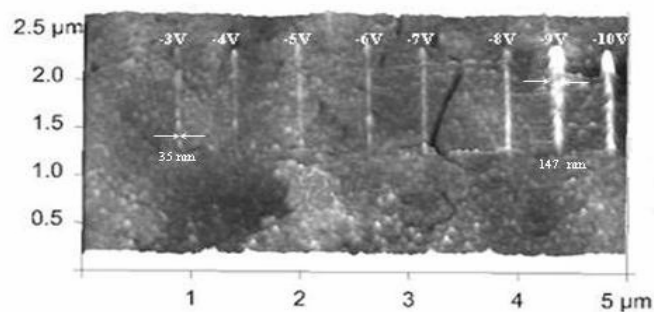

The polymer nanopatterns of line drawn at varying voltage of -3v to -10v at constant tip speed of $1\ \mu\text{m/s}$. Varying feature size ranging from $35\ \text{nm}$ to $250\ \text{nm}$ was observed.

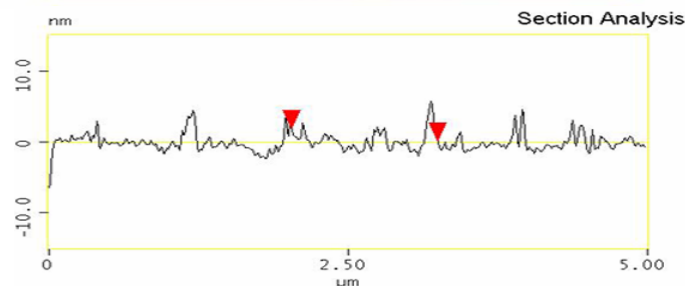
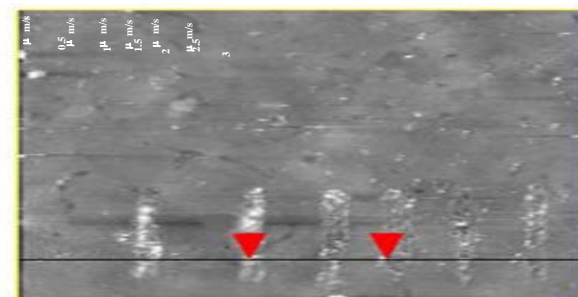

The nanopatterning of PVK film by writing lines with varying speed at constant voltage of -7v .

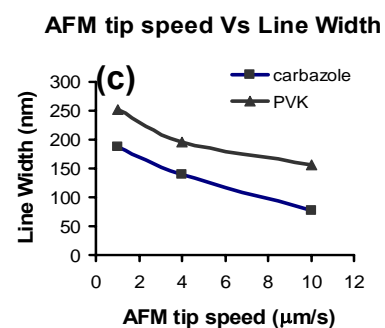
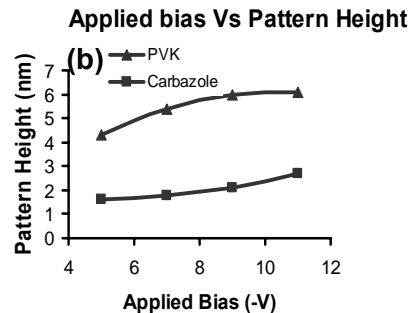
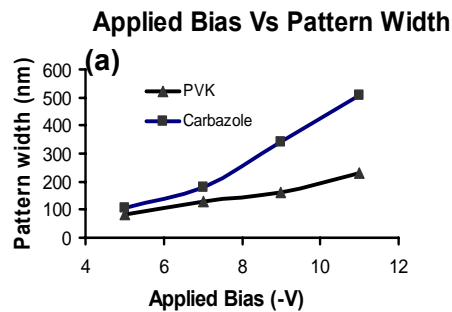



Geometric Patterns based on Voltage Bias and Speed

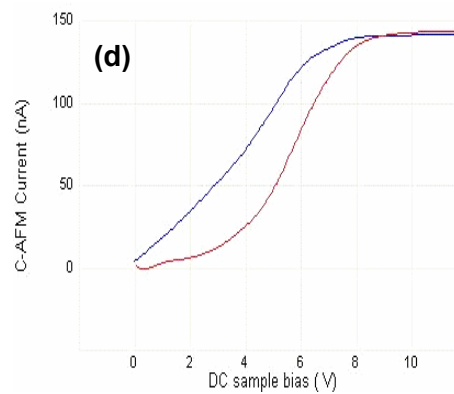
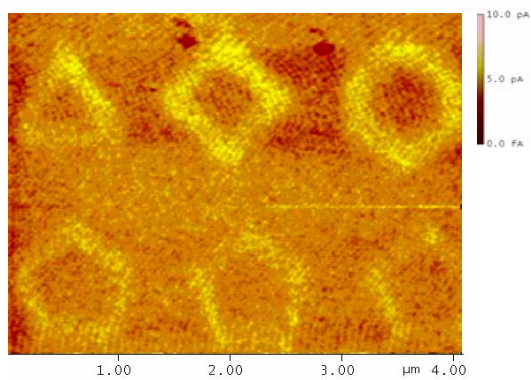
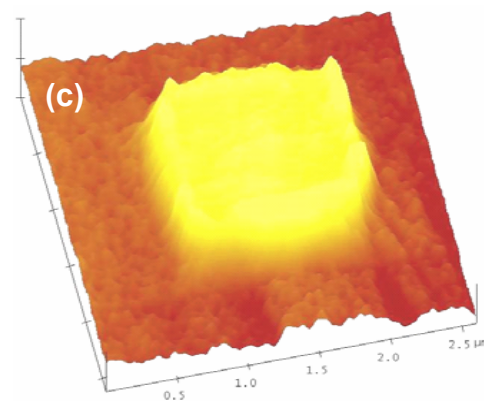
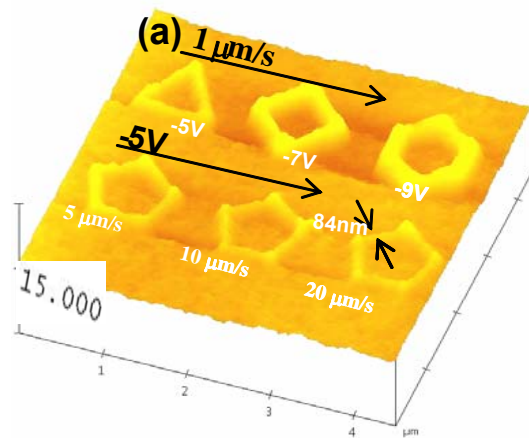

Valiyaveetil, S.; Advincula, R.; Subbiah
JACS **2005** submitted.



SPM Monitoring of Patterned-Electrodeposition of Polypyrrole

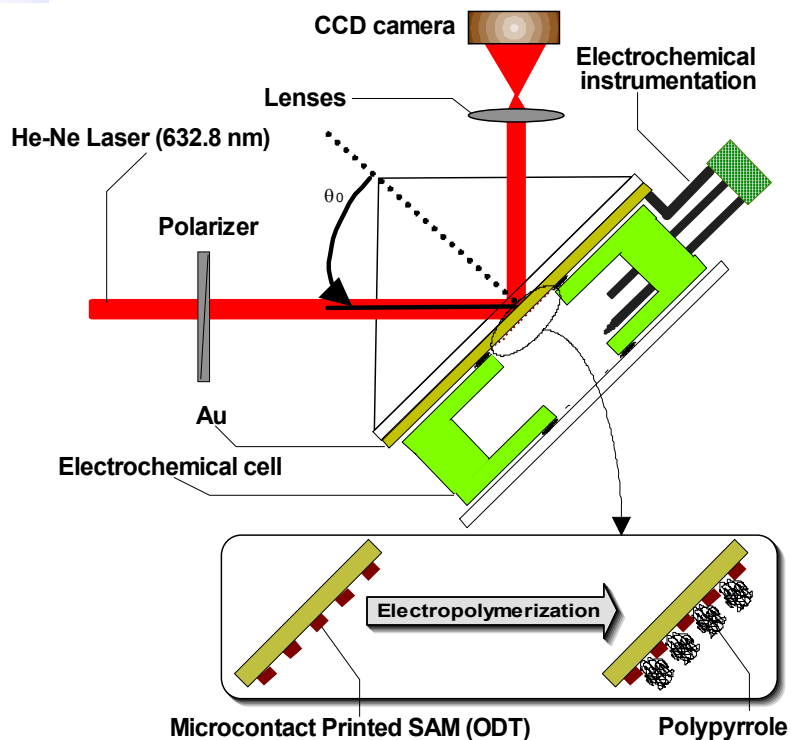

EC-SPM

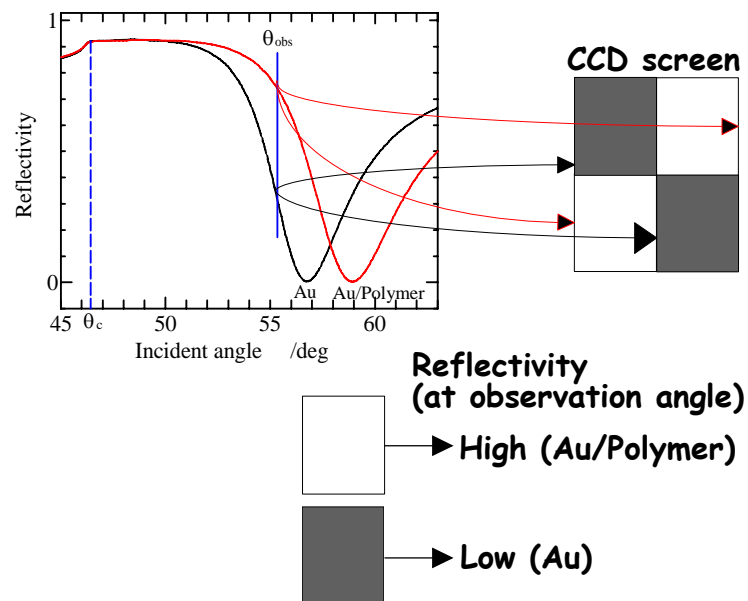

Experimental set-up for Electrochemical-surface plasmon microscopy (EC-SPM)

Baba, A.; Advincula, R.; Knoll, W. " Evaluation of Electropolymerization Process of Pyrrole on Micropatterned Self-Assembled Monolayers" *Polym Mat. Sci.Eng. Prep.(Am.Chem.Soc.,Div. PMSE)*, **2002** 86, 48.



Microcontact-printing of Octadecylthiol on Au

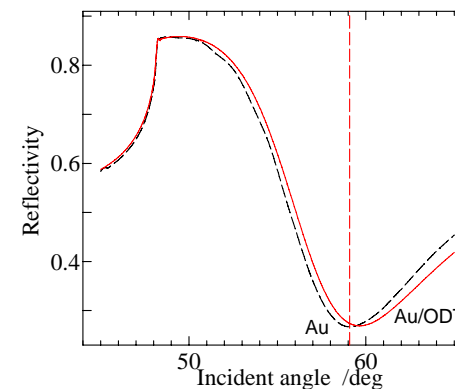
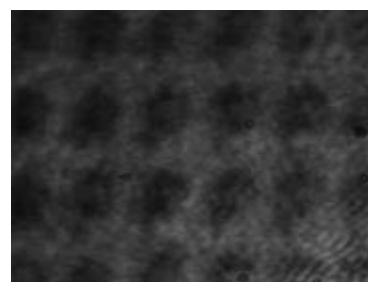
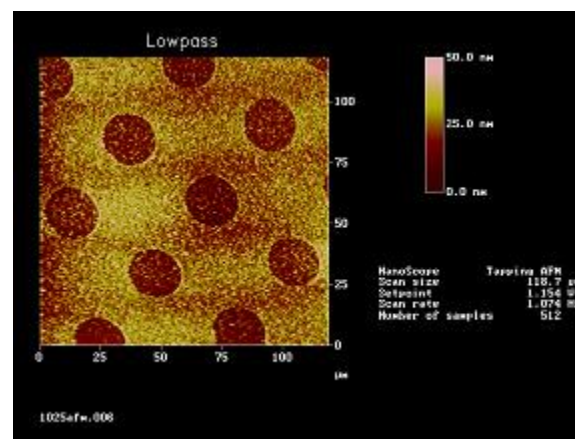
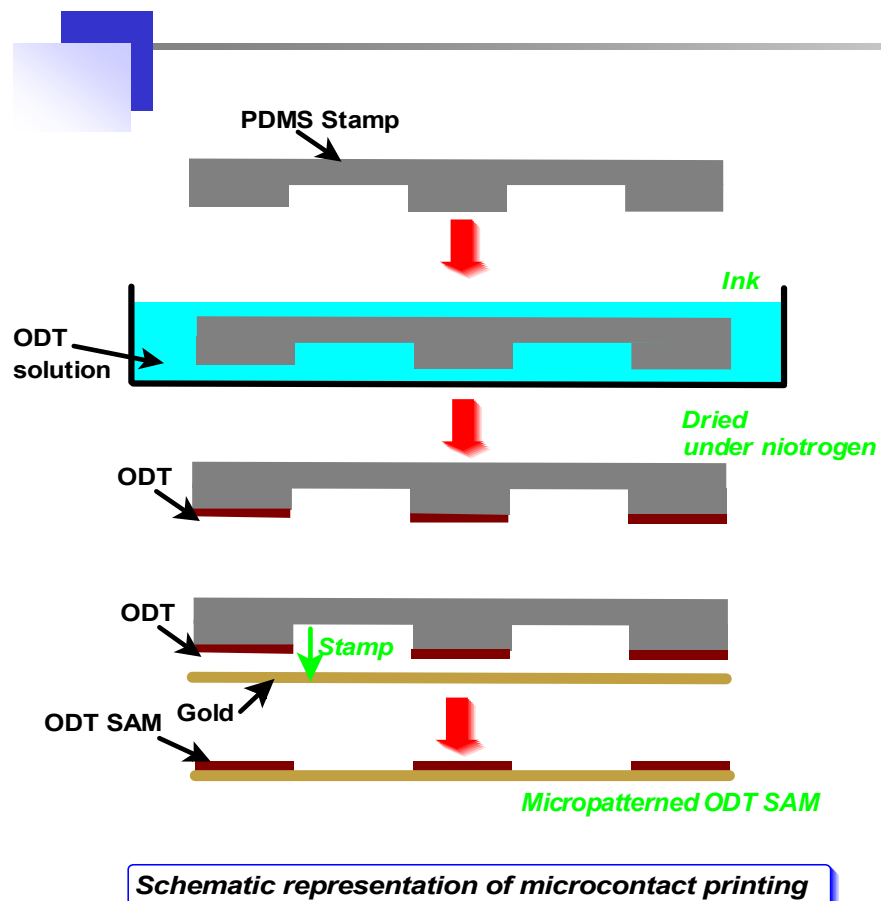

μCP Printing of ODT on Au, probed by SPS, SPM, and AFM: Resolution and patterning limits



Electropolymerization process of pyrrole on Micropatterned Self-assembled Monolayers: EC-SPM

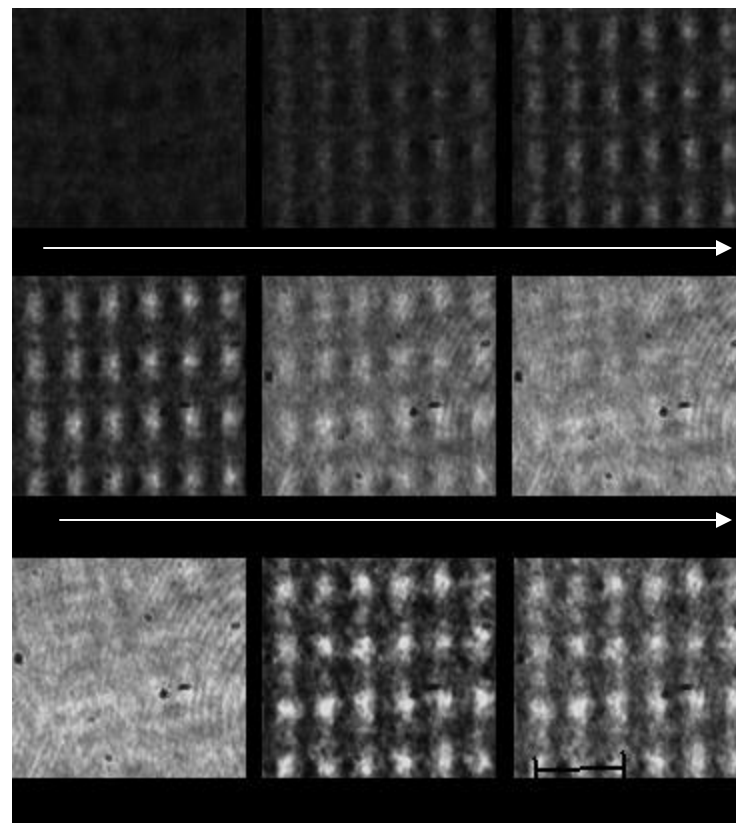
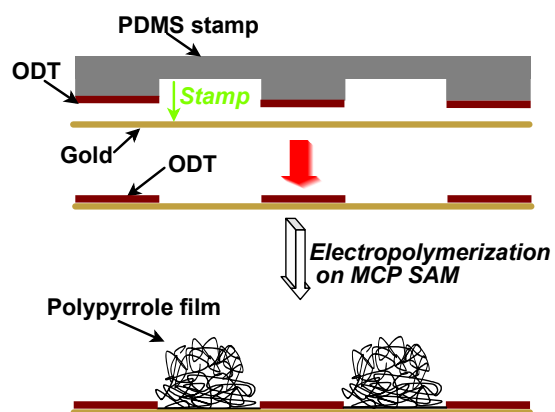
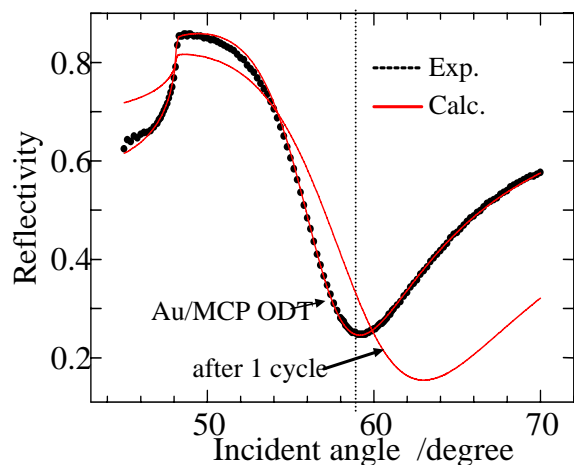

Change in reflectivity with polymer growth on pattern vs. Time - Different potential



EC-SPM: Different Angles and potentials

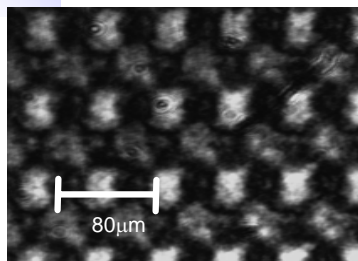

59.0°

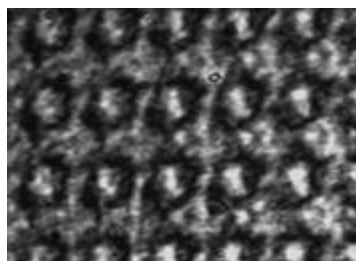

60.0°

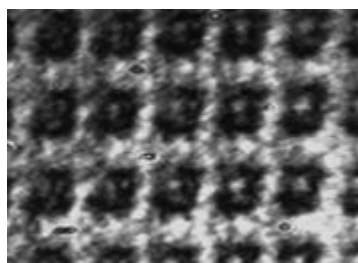

61.0°

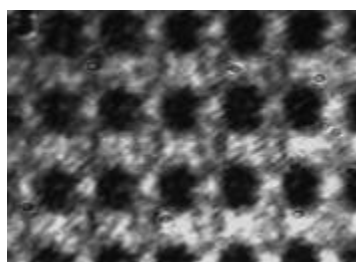

62.0°

- reflectivity changes with angle
- Sensitivity to thickness and dielectric constant
- reflectivity changes with potential

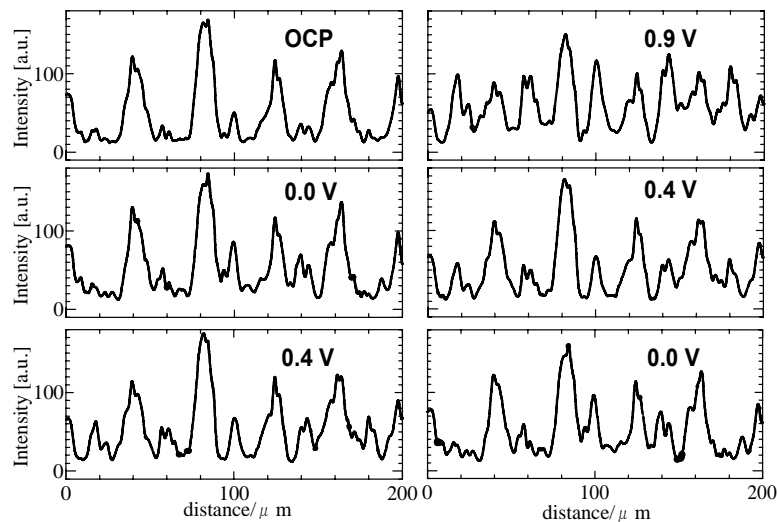
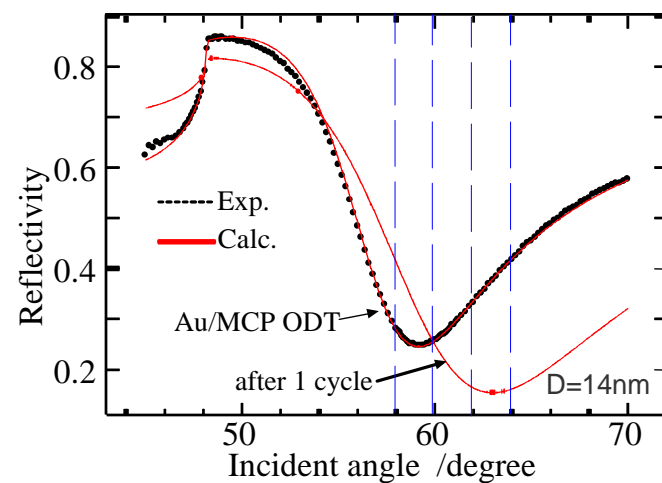



Outline of Projects

- ▶ **Project 1.** Electrodeposition and Patterning of Conjugated Polymers Using The Precursor Polymer Approach.
- ▶ **Project 2.** Nanostructured Ultrathin Films of Oligothiophenes and Dyes.
- ▶ **Project 3.** Living Anionic Surface Initiated Polymerization (LASIP) on Nanoparticles
- ▶ **Project 4.** Nanoparticle Synthesis Using Block Copolymer Micelles, Star Copolymers and Polyelectrolyte Complexes
- ▶ **Project 5.** Functional Dendrimers as Organic Nanoparticles
- ▶ **Project 6.** Hybrid Nanoparticle-Dendron Materials: Energy Transfer Phenomena
- **Conclusions**



Project 2

Nanostructured Ultrathin Films of
Oligothiophenes and Functional Dyes.

NSF-CAREER: DMR 99-82010



Application ... FET Devices

Field Effect Transistor (FET) Devices

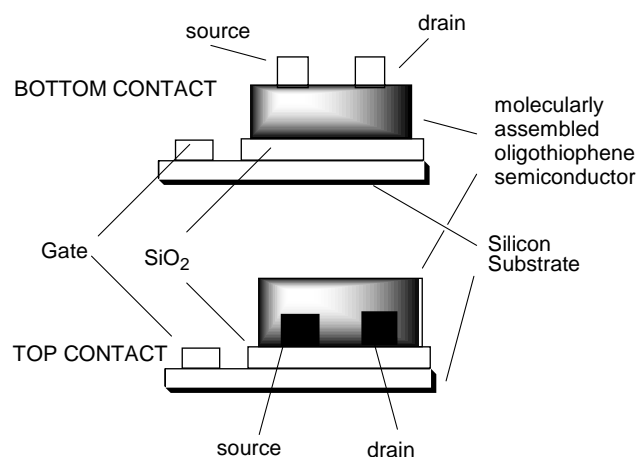

- Semiconductor layer supports a channel of holes (p-type) or electrons (n-type) between the source and drain electrodes.

- Density of charge carriers in the channel is modulated by voltage applied through the gate electrode.

- The most important criteria for a FET semiconductor are: high charge carrier mobility, high current modulation (on/off current ratio), stability, and processability.

$$I_{DS} = \frac{WC_t}{2L} \mu (V_G - V_D)^2$$

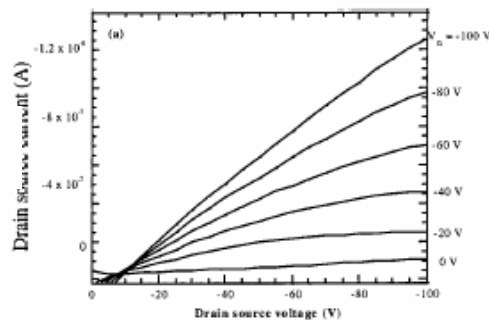

Bao, Z.; Lovinger, A.. *Chem. Mater.* **1999**, *11*, 2607-2612



Ultrathin Films: nanometers to μm

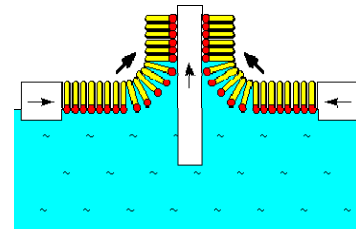
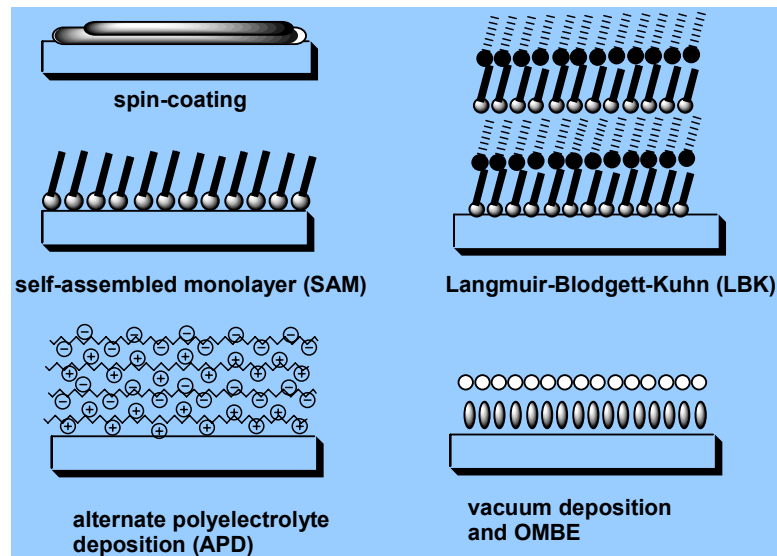

- Thickness of a few nm to μm
- Solution, interface, vacuum methods
- Substrate support or free-solution entities (micelles, lipids)
- Multilayer films
- Superlattice structures
- Epitaxy

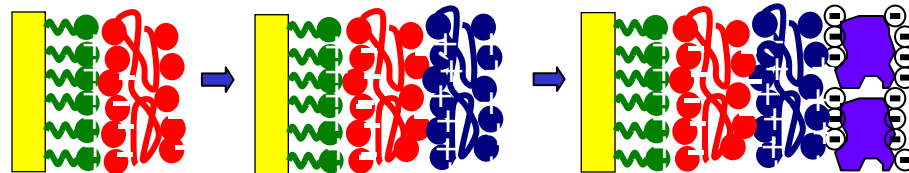
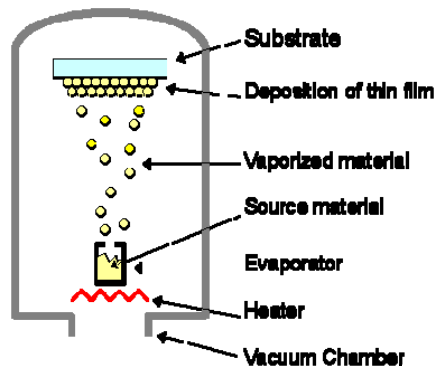



Nanostructured Layer-by-layer Self-assembly

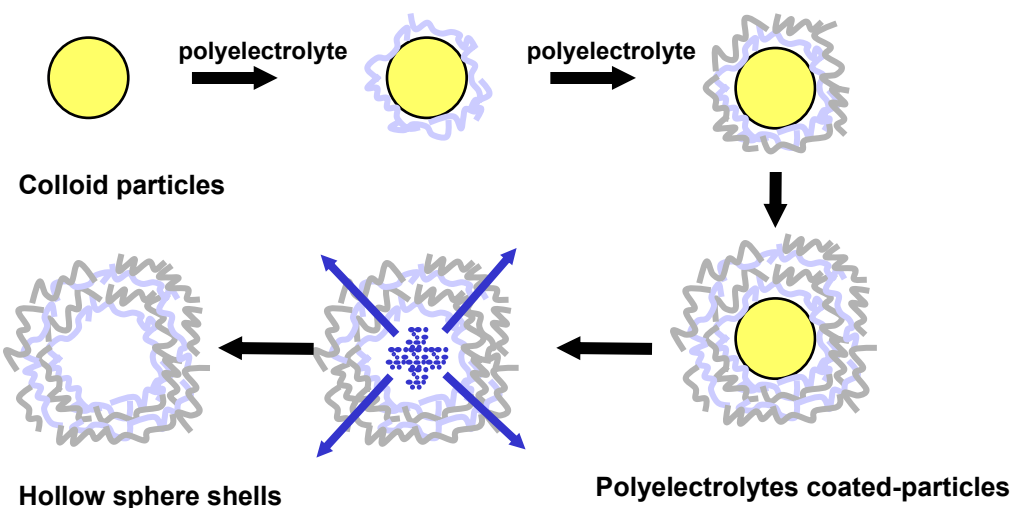
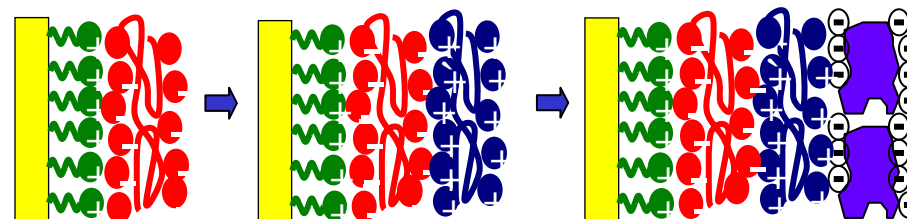
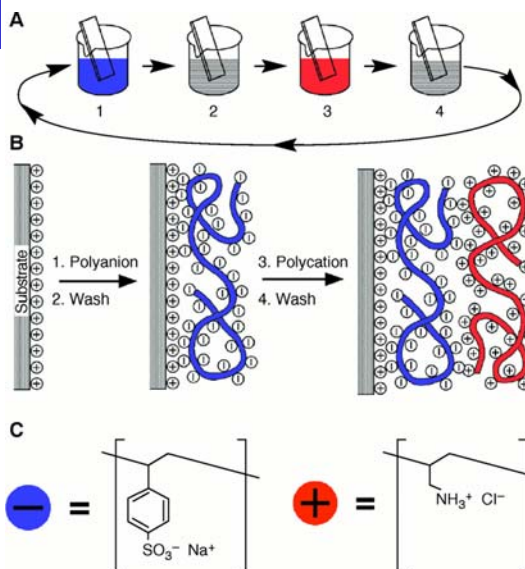

- Electrostatic (coulombic forces)
- Interfacial phenomena and colloids
- Solution properties: concentration, pH, salts, temperature
- Surface sensitive techniques



Layer-by-Layer in the Advincula Research Group

www.nanostructure.uh.edu

Nanostructured Layer-by-layer Organic and Polymer Materials

- Photoalignment films with dyes
 - PLED and FET devices
 - Biofunctional Films for Microarrays and Sensors
 - ph-Sensitive Ion-Permselective Membranes
 - Functional Colloidal Particles
-
- Advincula, R. et.al. *J. Am. Chem. Soc.* **2004**, *126*, 13723-13731.
 - Advincula, R. et.al. *Chem. Mater.* **2004**, *16*, 5063-5070.
 - Advincula, R. et.al. *Langmuir* **2003**, *19*, 8550-8554.
 - Advincula, R. et.al. *Langmuir* **2003**, *19*, 654-665.
 - Advincula, R. et.al. *Langmuir* **2003**, *19*, 916-923.
 - Advincula, R. et.al. *Chem. Mater.* **2003**, *15*, 1404-1412.
 - Advincula, R. et.al. *Colloids Surf. A* **2002**, *198-200*, 917-922.
 - Advincula, R. et.al. *Langmuir* **2002**, *18*, 4532-4535.
 - Advincula, R. et.al. *Langmuir* **2002**, *18*, 4648-4652.
 - Advincula, R. et.al. *Chem. Mater.* **2002**, *14*, 2184-2191.



Project 2a. Cross-Linked, Luminescent Spherical Colloidal and Hollow-Shell Particles

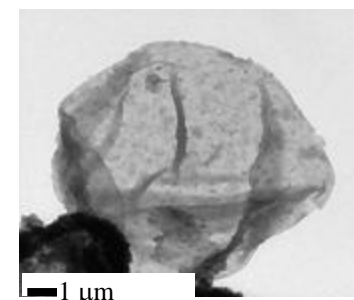
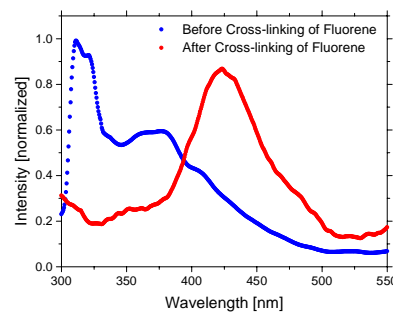
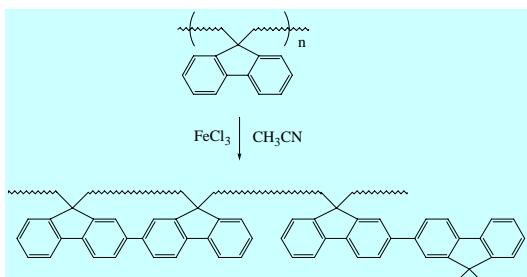
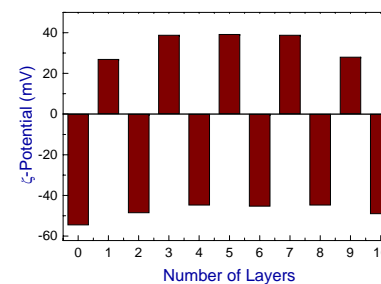
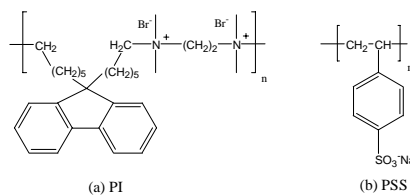
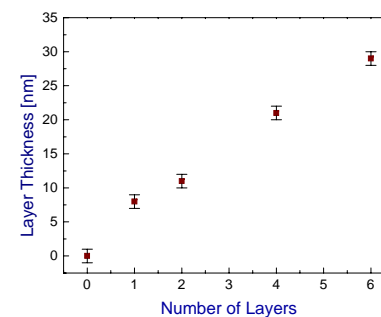
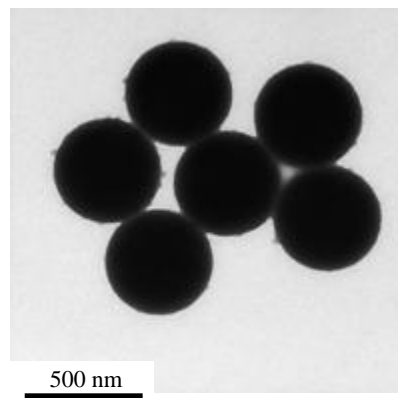
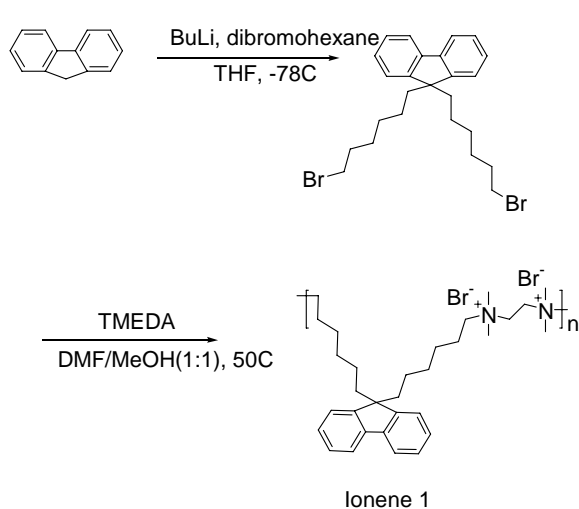

Park, M-K.; Xia, C.; Schütz, P.; Caruso, F. Advincula, R. "Cross-Linked, Luminescent Spherical Colloidal and Hollow-Shell Particles" *Langmuir*, **2001**, *17* (24), 7670 -7674.



Project 2b. Nanostructured Films of Oligothiophenes using the Layer-by-layer Approach

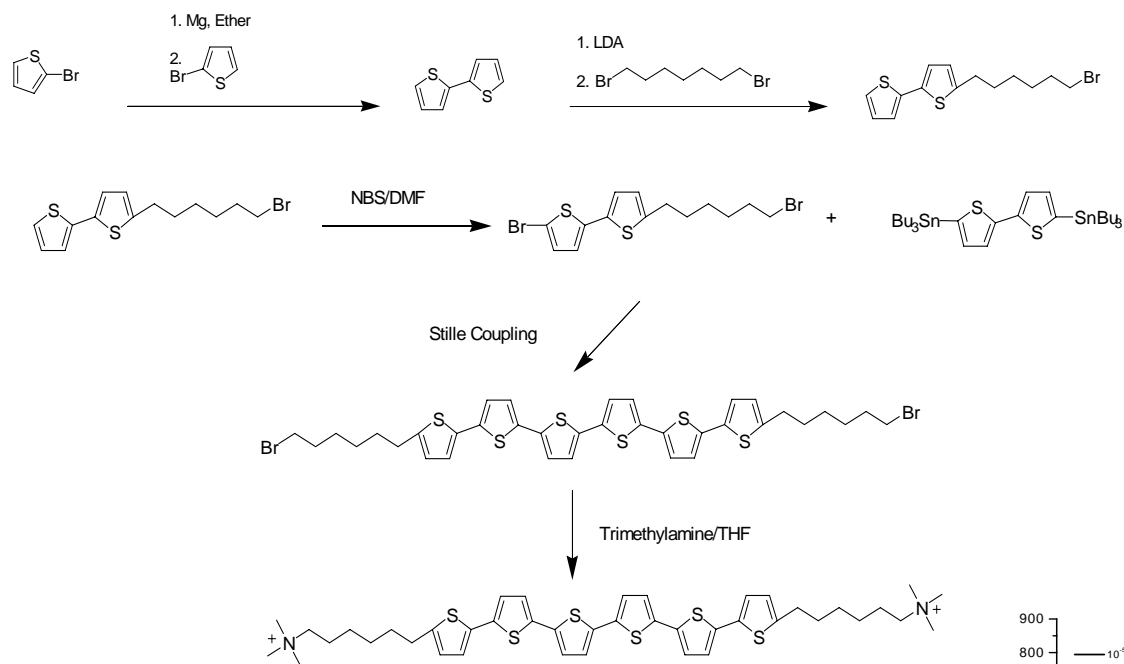

- water soluble
- bolaform amphiphile
- Distinct aggregation
- fluorescence and absorption

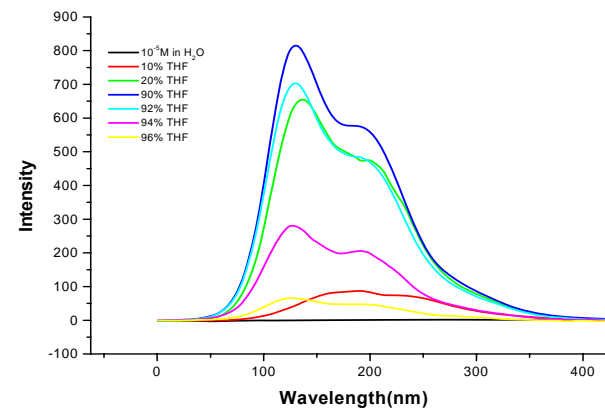
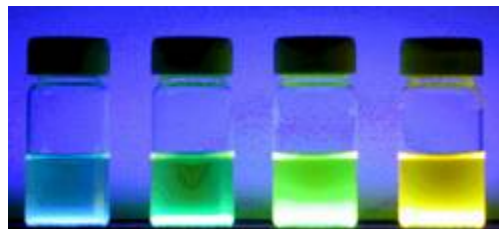
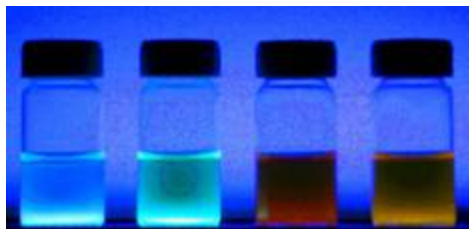

Xia, C.; Locklin, J.; Youk, J.; Fulghum, T.; Advincula, R. "Distinct Aggregation and Fluorescence Properties of a Water-Soluble Oligothiophene (6TN) Bolaform Amphiphile, *Langmuir* **2001**; 18(3); 955-957. .



Spectroscopic, Ellipsometric, and SPS Characterization

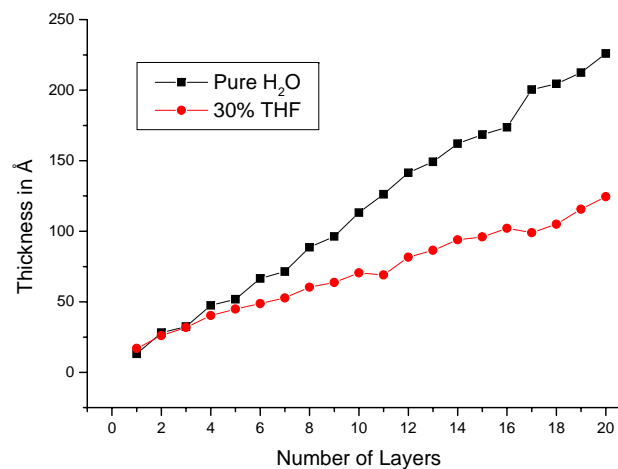
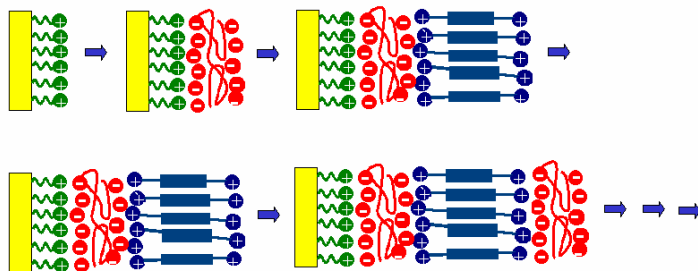
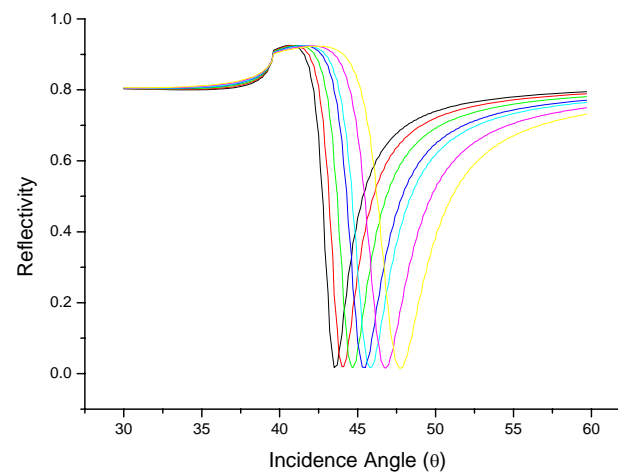
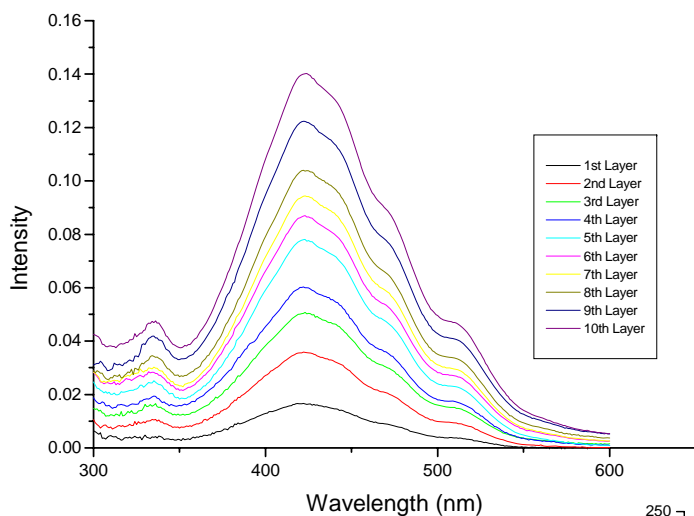

Average Layer Thickness
Pure H₂O
+6T+= 13.01 Å
PSS = 9.25 Å

30% THF
+6T+= 6.88 Å
PSS= 4.30 Å

R. Advincula, J. Locklin, J. Youk, C. Xia, M.K. Park, X. Fan "Nanostructured Ultrathin Films of Water-soluble Sexithiophene Bolaform Amphiphiles Prepared Using Layer-by-Layer Self-Assembly"- *Langmuir* **2001**; 18(3); 877-883.



AFM and XPS Characterization

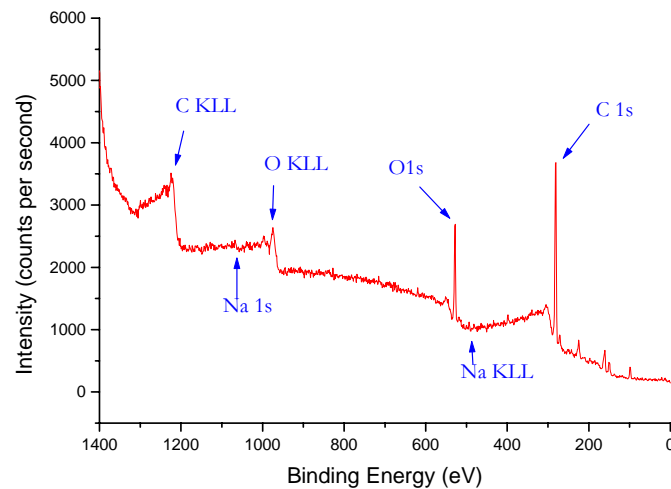
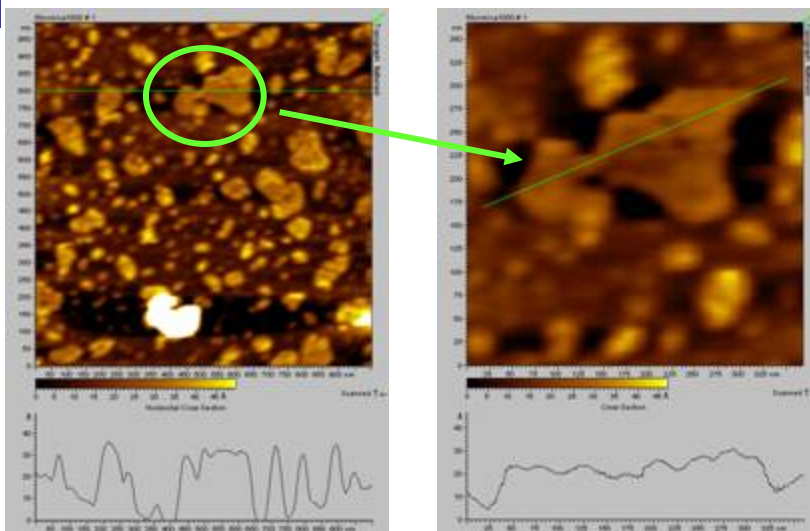

Langmuir **2001**; 18(3); 877-883.

Fan, X.; Locklin, J.; Youk, J. H.; Blanton, W.; Xia, C.; Advincula, R.; "Nanostructured Sexithiophene/Clay Hybrid Multilayers: A Comparative Structural and Morphological Characterization", *Chem. Mater.* **2002**; 14(5); 2184-2191.

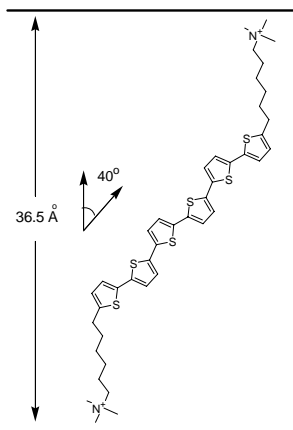

Average aggregate size from AFM = 31.7 Å

Calculated tilt angle of aggregate from substrate = 58°

Tilt angle of 6T component = 18-22°



Transistor Activity: p- and n- channel

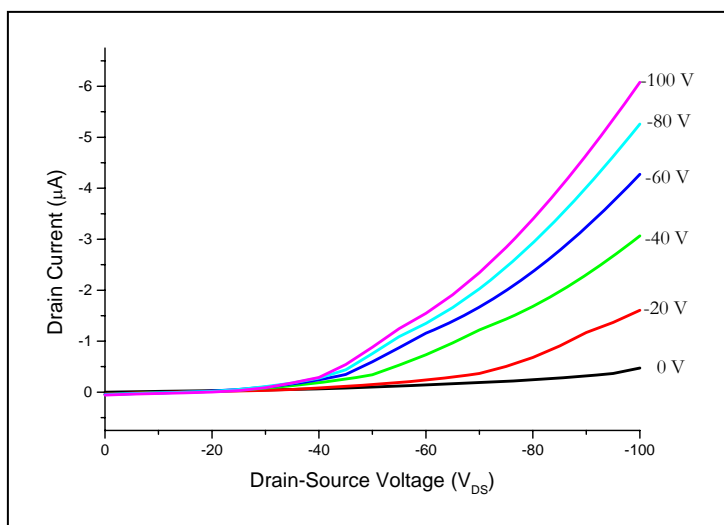

Mobility: $0.008 \text{ cm}^2/\text{V}\cdot\text{s}$

On/Off ratio: 10

V_{DS} from 0 to -100 V in 5 V increments

V_G from 0 to -100 V in 20 V increments

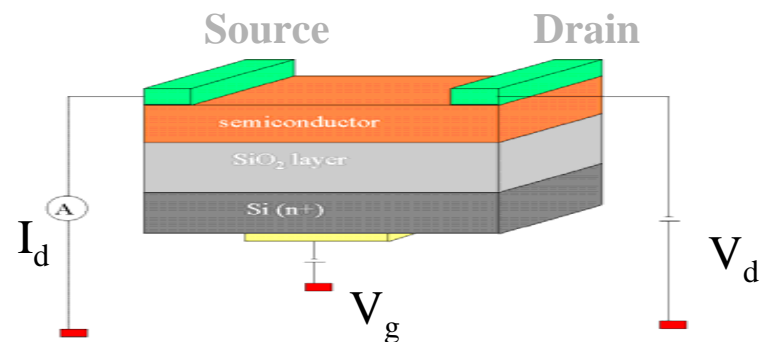
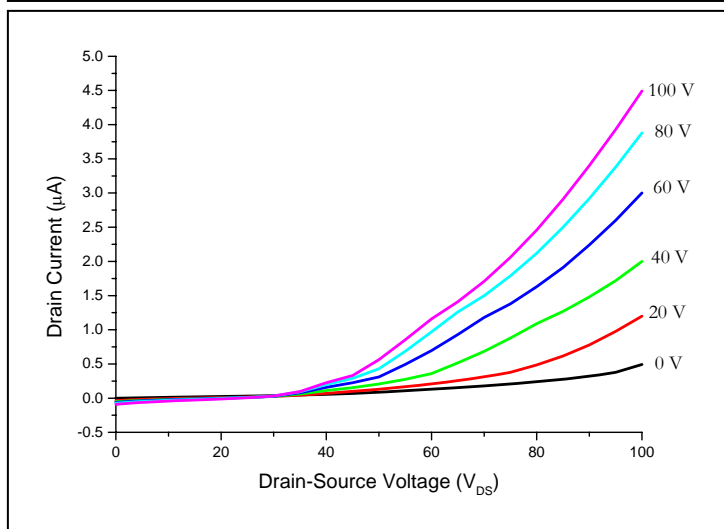

Mobility: $0.006 \text{ cm}^2/\text{V}\cdot\text{s}$

On/Off ratio: 9

V_{DS} from 0 to 100 V in 5 V increments

V_G from 0 to 100 V in 20 V increments

6TN (in 0.03 M NaCl) was solution cast onto polyelectrolyte covered Si wafer and solvent was evaporated under precise conditions



Layer-by-layer Phthalocyanine Ambipolar FETs

Ambipolar Organic Thin Film Transistor-like Behavior of Cationic and Anionic Phthalocyanines Fabricated Using Layer-by-Layer Deposition from Aqueous Solution

Jason Locklin,^{†,‡} Kazunari Shinbo,[§] Ken Onishi,[†] Futao Kaneko,[§]
Zhenan Bao,^{*,¶} and Rigoberto C. Advincula^{*,‡}

Chem. Mater. **2003**, *15*, 1404–1412

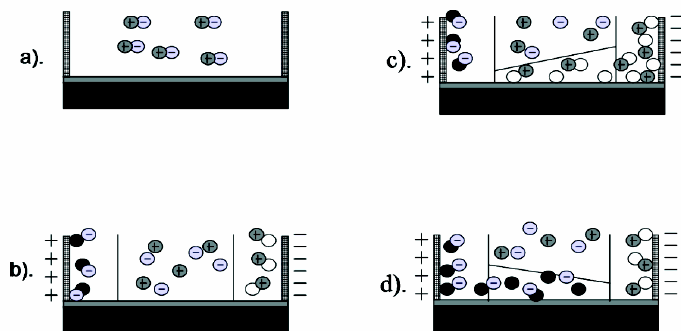
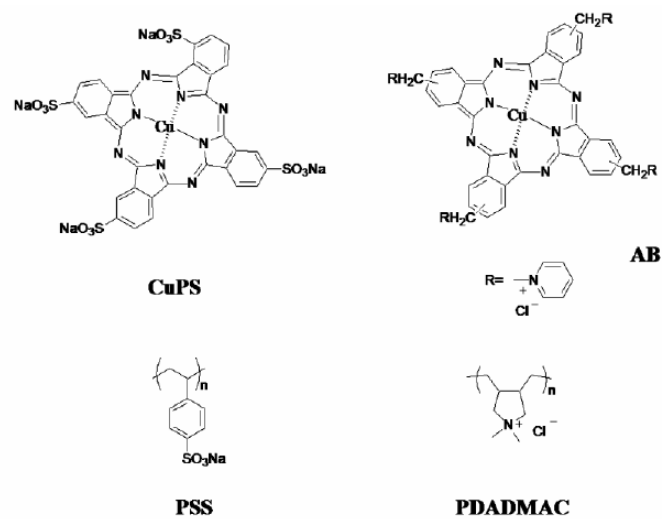

Figure 9. Schematic diagram of the proposed ambipolar transistor mechanism: (a) idle state; (b) off state; (c) on state for n-type, and (d) on state for p-type (○ reduced molecules, ● oxidized molecules, ⊕ cations from ionic species, ⊖ anions from ionic species).

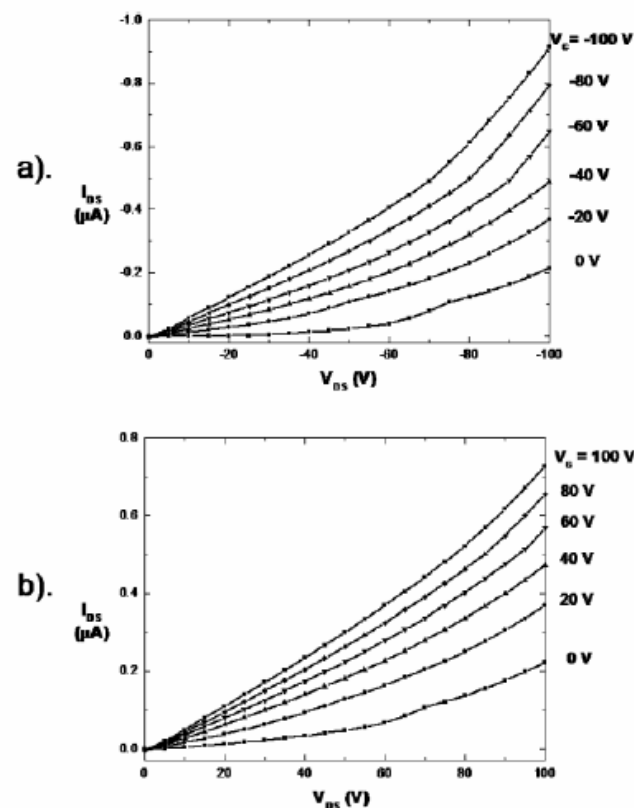
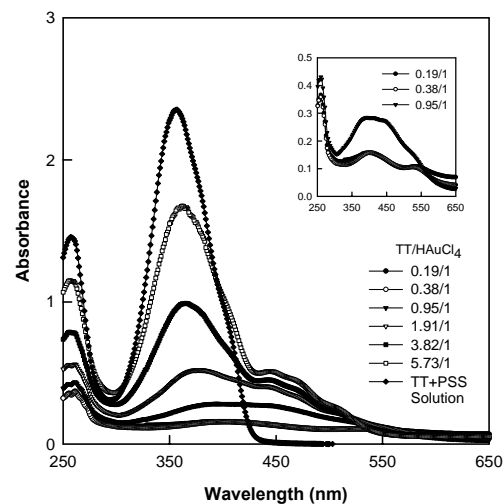
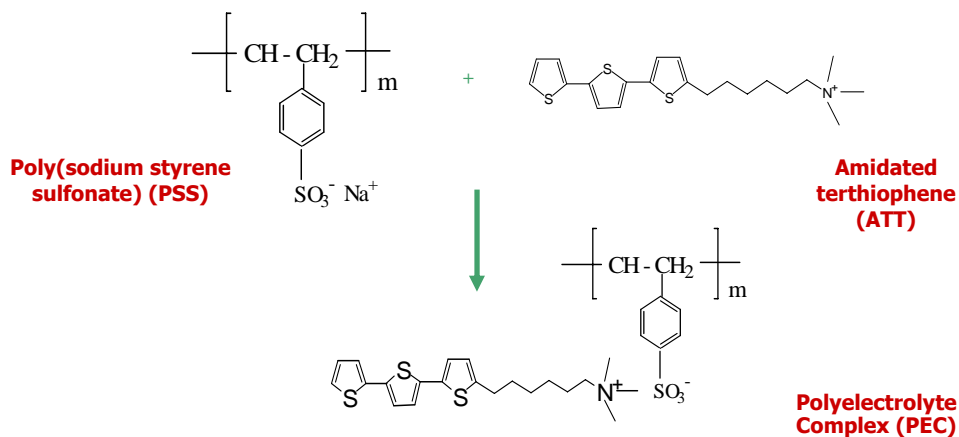
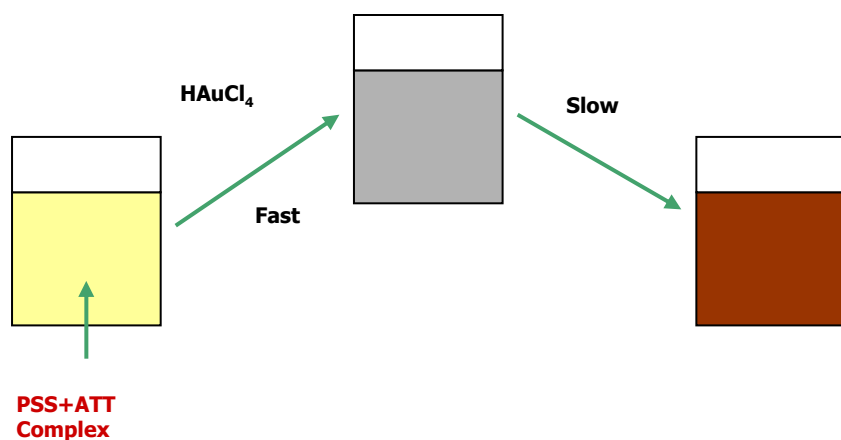

Figure 7. Typical I_{DS} vs V_{DS} curves at (a) negative and (b) positive gate bias for the AB/CuPS multilayers fabricated from 0.03 M NaCl solution with a gap of 14 μm .



Project 2c. Nanoparticle formation from Polyelectrolyte Complexes of Sexithiophenes



- Suggestion of Mayer and Mark (*Eur. Polym. J.*, 1998, 34, 103)
- 1. Polymer containing sulfur would have the high affinity to gold surfaces
- 2. Polymer possessing reducing groups could be very suitable
- PSS increased the solubility of terthiophene amphiphile



Coupling of Terthiophenes to form Sexithiophenes simultaneous with nanoparticle formation

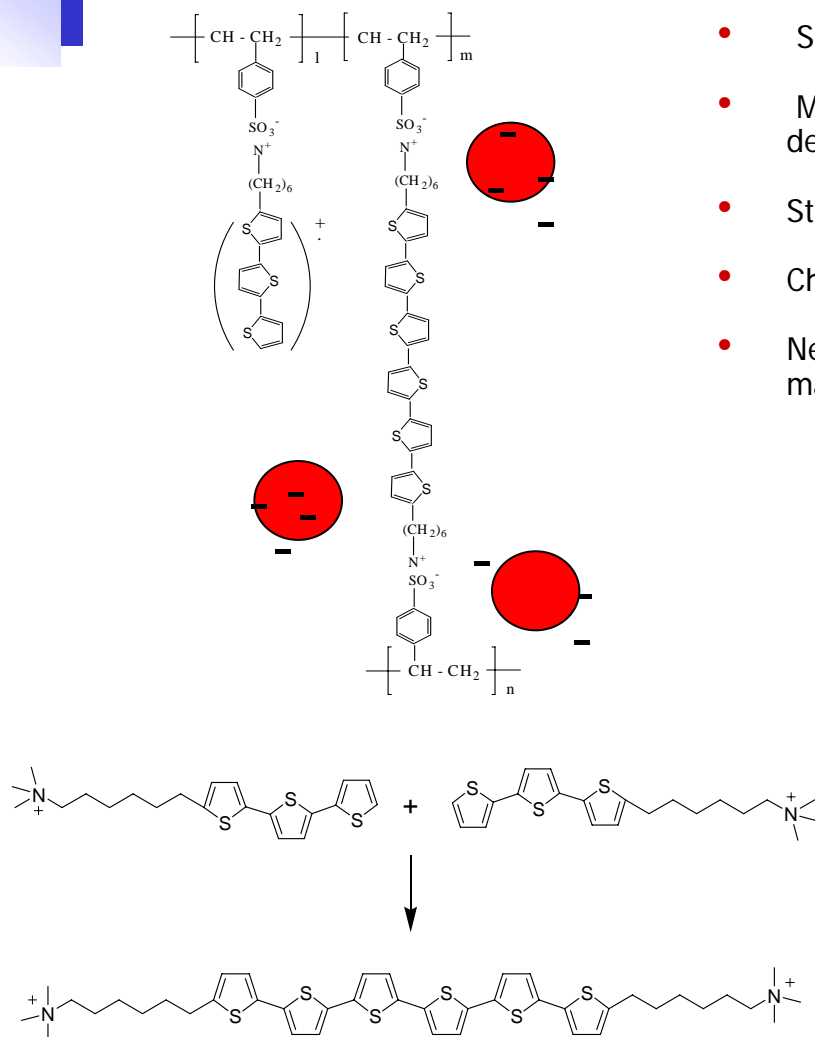

- Sexithiophene bolaform amphiphile formation
- Mechanism (electrochemical or oxidative) needs to be determined
- Stabilization of gold particles is very important
- Characterization of complexes is very important
- New materials combining metallic, semi-conductor and organic materials: interesting electrical and optical properties.

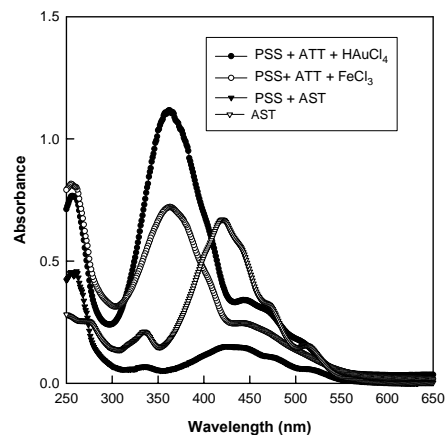



TEM Characterization

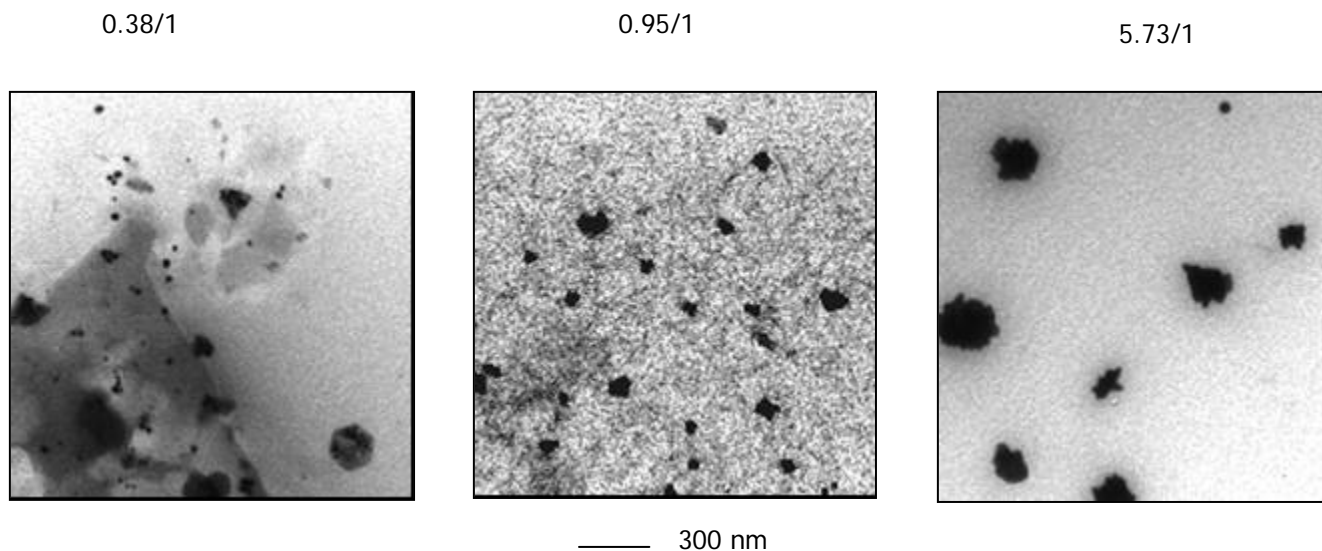

- As the terthiophene concentration increases, the size of nanoparticles increases
- Nanoparticle partially stabilized: inhomogeneous growth and aggregation
- Increase in size, loss of spectroscopic properties associated with nanoparticle

Youk, J. H.; Locklin, J.; Xia, C.; Park, M.K. and Advincula, R.” Preparation of Gold Nanoparticles from a Polyelectrolyte Complex Solution of Terthiophene Amphiphiles” *Langmuir* **2001** 17(15); 4681-4683.



LBL Films as Nanoreactor Hosts for Nanoparticle Synthesis

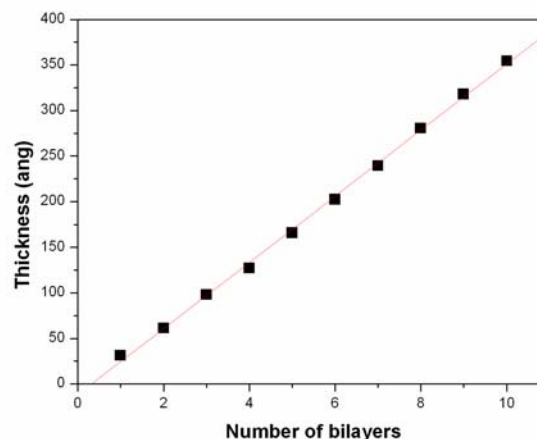
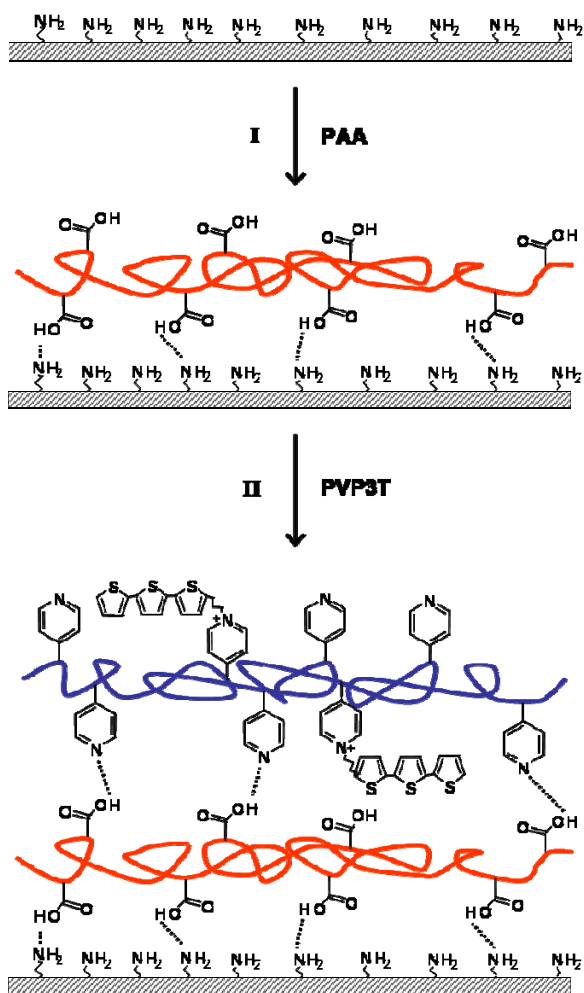

- REDOX reaction occurs between the terthiophene moiety and the Au precursor with formation of Au Nanoparticles and sexithiophene
- Au nanoparticle partially stabilized by the PE complex resulting in irregular growth and aggregation

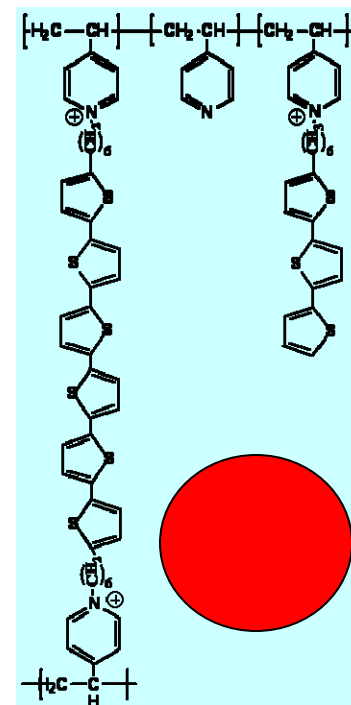

**Preparation of Gold Nanoparticles with PSS:
Water-soluble Terthiophene Complex**
(Youk et al. Langmuir 2001, 17, 4681.)



Gold Nanoparticle Formation in LBL Multilayer Films

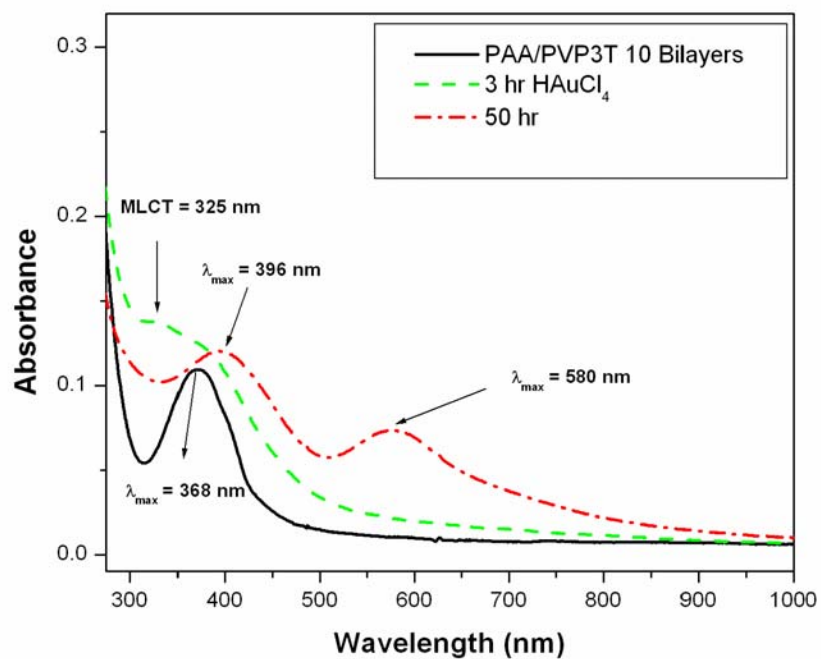

- Red-shift in absorbance of the 3T moiety from 368 to 396 nm attributed to coupling of the terthiophene units to form sexithiophene with simultaneous formation of Au nanoparticles (surface plasmon peak = 580 nm)
- Position of the Au SP band and presence of broad absorption tail around 700 nm indicate aggregation and/or particles that deviate from a spherical geometry

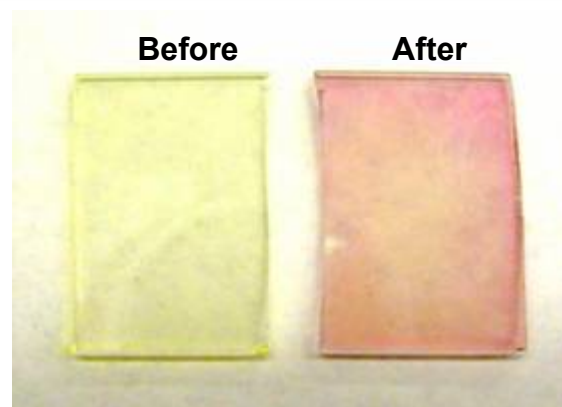
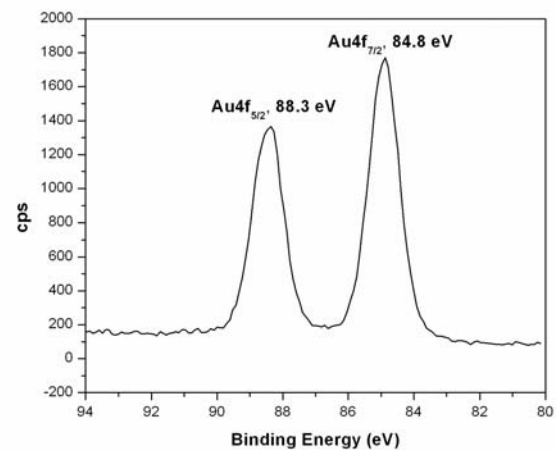

J. Phys. Chem. B **1999**, 103, 7441.
Adv. Mater. **1998**, 10, 133.



TEM Imaging

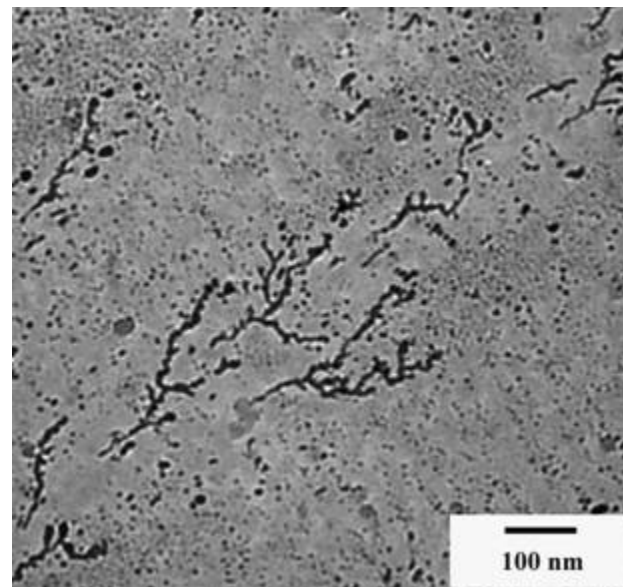
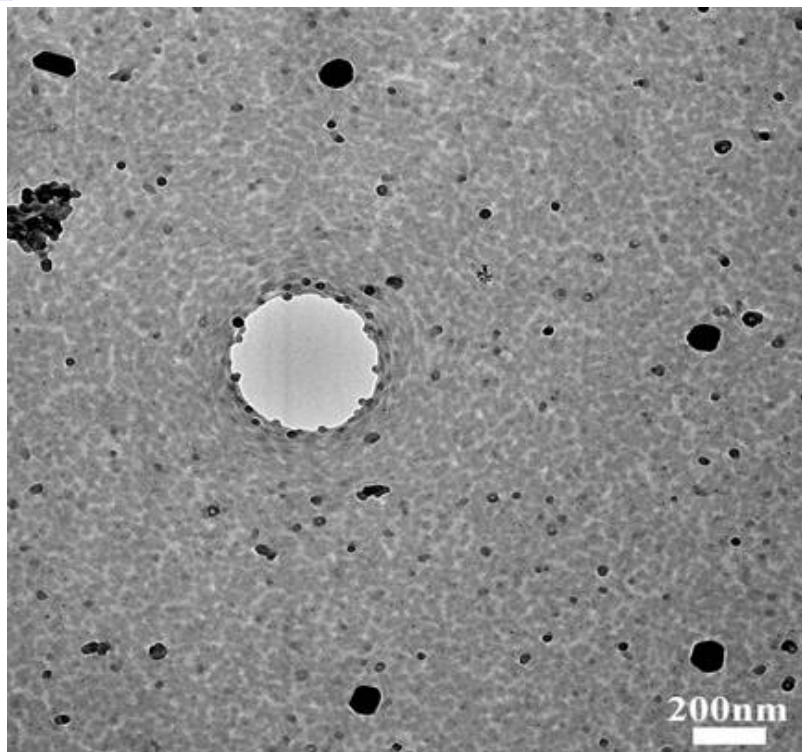

TEM image of a 3 bilayer PVP3T/PAA film containing Au nanoparticles after ~ 50 hrs at 60 °C/95% humidity. Scale bar = 200 nm.

TEM image depicting dendritic nanostructures formed with the PVP3T/PAA thin film.



Outline of Projects

- ▶ **Project 1.** Electrodeposition and Patterning of Conjugated Polymers Using The Precursor Polymer Approach.
- ▶ **Project 2.** Nanostructured Ultrathin Films of Oligothiophenes and Dyes.
- ▶ **Project 3.** Living Anionic Surface Initiated Polymerization (LASIP) on Nanoparticles
- ▶ **Project 4.** Nanoparticle Synthesis Using Block Copolymer Micelles, Star Copolymers and Polyelectrolyte Complexes
- ▶ **Project 5.** Functional Dendrimers as Organic Nanoparticles
- ▶ **Project 6.** Hybrid Nanoparticle-Dendron Materials: Energy Transfer Phenomena
- **Conclusions**



Project 3

Living Anionic Surface Initiated Polymerization
(LASIP) on Surfaces and Nanoparticles:
Preparation of Nanocomposites

Army (ARO): DAAD19-99-1-0106



Grafting Methods for Polymer Brushes

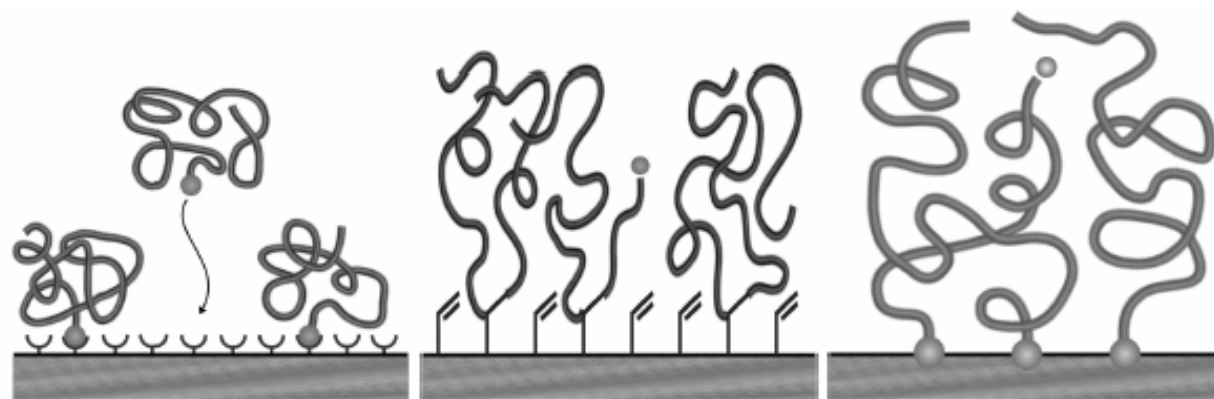

“grafting to” surface bound monomer “grafting from” or SIP

Why Surface Initiated Polymerization (SIP)?

- High brush density: ave. distance b/w grafting points $<$ radius of gyration (R_g).
- Functionalized surfaces, controlled surface energies, controlled surface chemistry
- different methods of initiation: free-radical, ATRP, cationic, anionic, etc.
- Model polymerization studies in confined environments
- Novel and advanced materials, colloidal particle stabilizers, polymeric surfactants, nanotechnology



Project 3a. Living Anionic Surface Initiated Polymerization on Surfaces: Nanostructured Surfaces

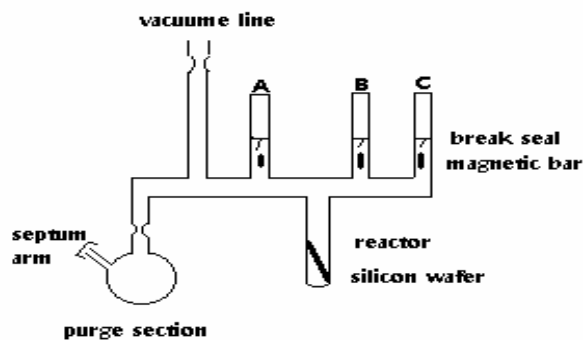
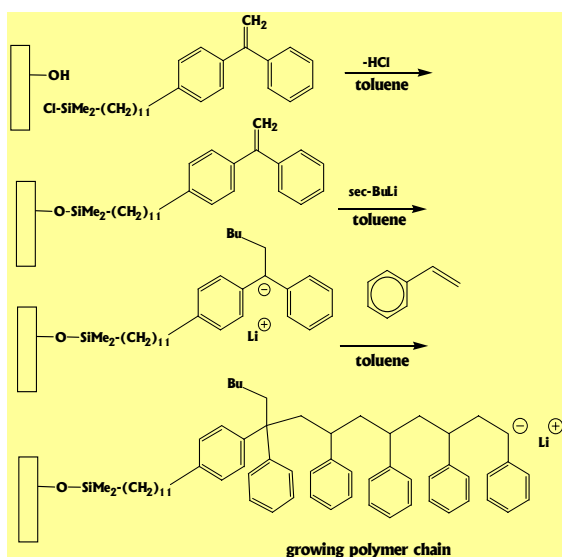
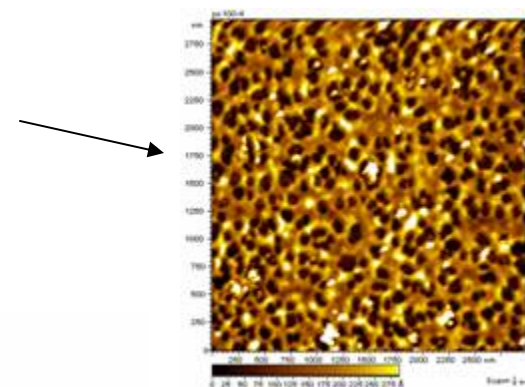
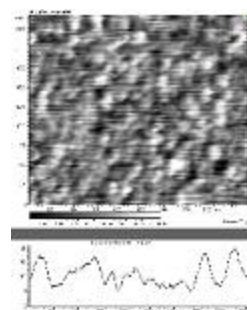
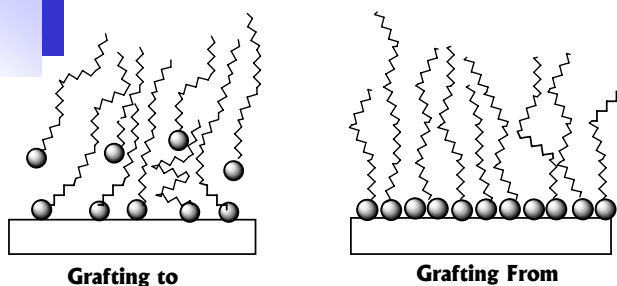

- **Polymer Brushes**
- **Why Surface Initiated Polymerization (SIP)?**
- **Living Anionic SIP**

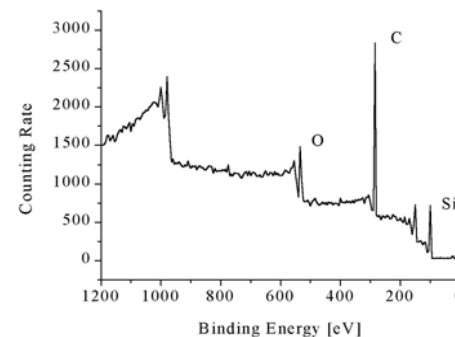

Zhou, Q.; Nakamura, Y.; Inaoka, S.; Park, M.; Wang, Y.; Mays, J.; Advincula, R. in *Polymer Nanocomposites*, ACS Symposium Series 804, Edited by. Krishnamoorti, R. and Vaia, R. Oxford University Press, North Carolina, 2002.



SIP of Block Copolymers at Si and Au surfaces/substrates

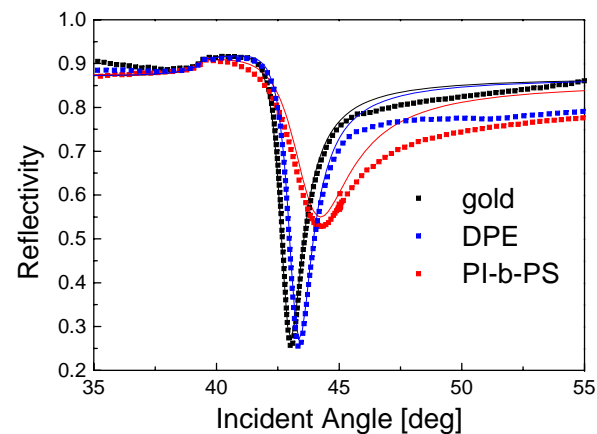
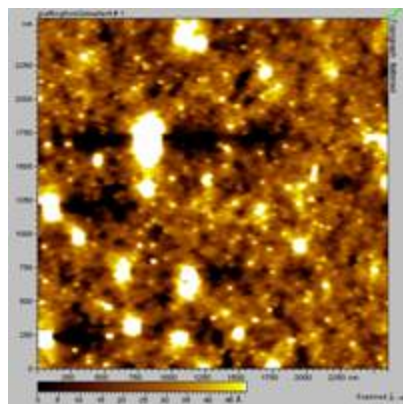
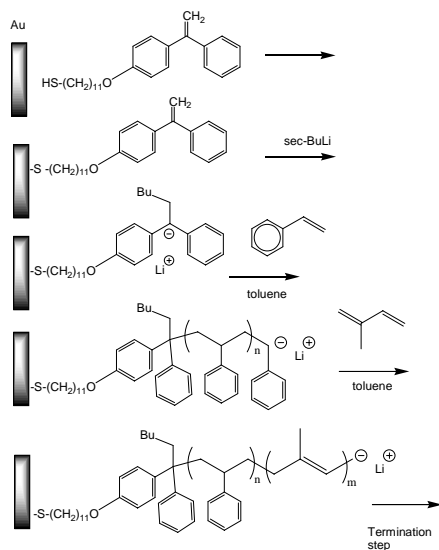

Grafting from

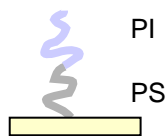

Thickness = 6 nm \pm 2 nm
 $\Delta m = 4.3 \times 10^{-5}$ g/cm²

Advincula, R. et. al. Polymer Brushes by Living Anionic Surface initiated polymerization (LASIP) on surfaces, *Langmuir*, **ASAP** article.

Zhou, Q.; Wang, S.; Fan, X.; Pispas, S.; Sakellariou, G.; Hadjichristides, N.; Mays, J.; Advincula, R. *Polymer Preprints (Am. Chem. Soc.)*, **2001**, 42, 59.

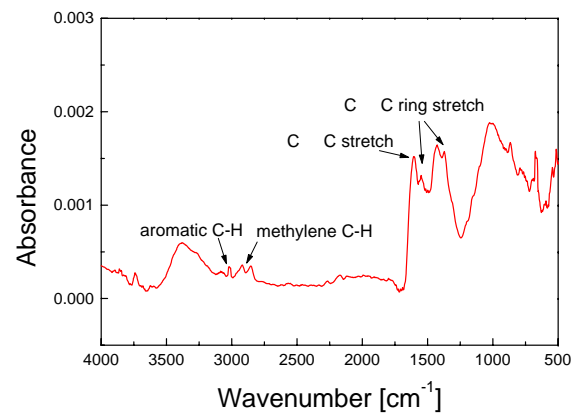



Project 3b. Nanocomposite Materials Prepared by Surface Initiated Anionic Polymerization from Nanoparticles

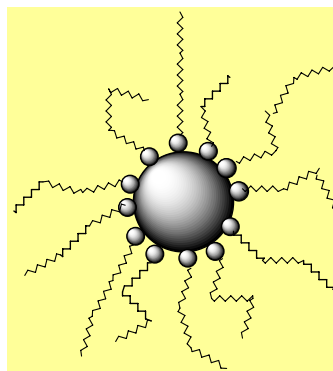
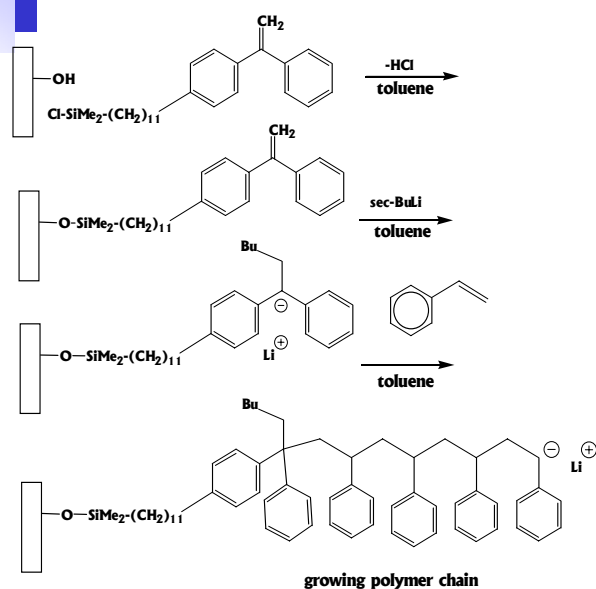

12-20 nm diameter

- grafting from Si-nanoparticle surface by silane coupling
- Immobilization of the DPE derivative on silica surface

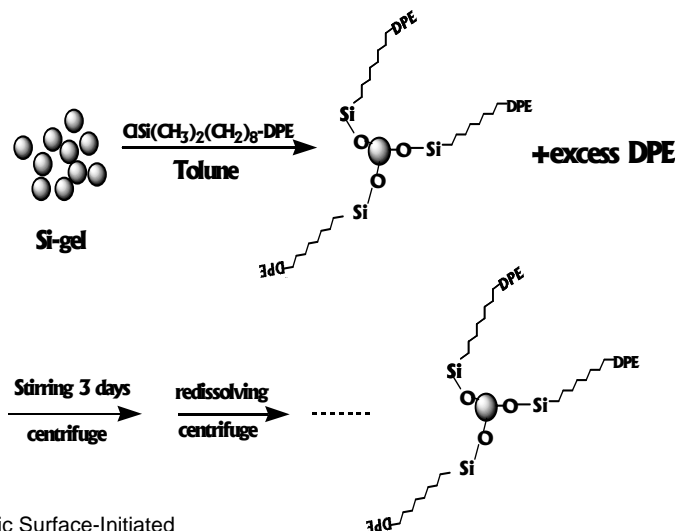

- **Polymer Brushes**
 - physisorption "grafting to", chemisorption "grafting from"
- **Why Surface Initiated Polymerization (SIP)?**
 - Novel, advance materials, colloidal particle stabilizer, polymeric surfactants
 - Model studies in confined environments
- **Living Anionic SIP**
 - Polymer conformation control, Higher brush density
 - Block and graft copolymers



LASIP on Si Nanoparticle Results

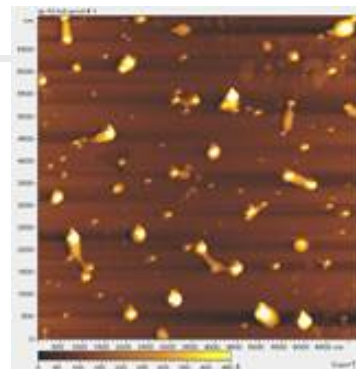
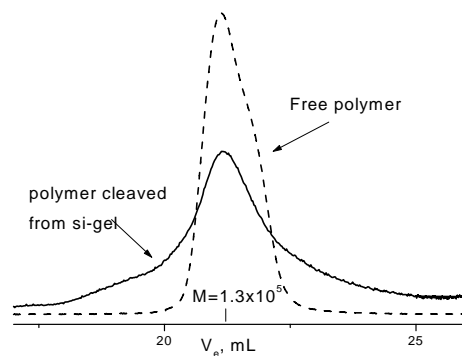
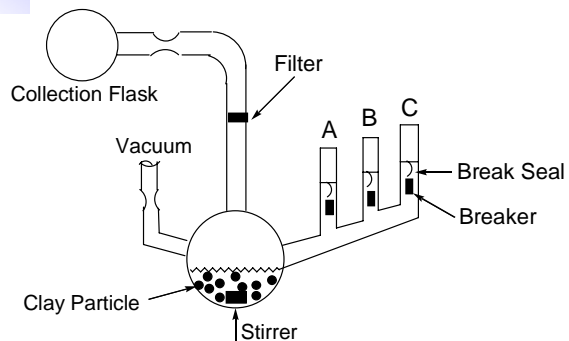

- Broader Polydispersity on grafted polymer
- Living anionic polymerization mechanism demonstrated
- TGA results suggests stable grafted polymers

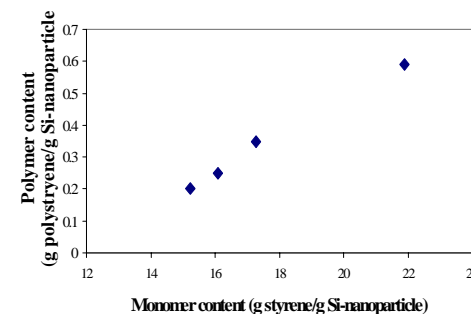

LASIP on Clay nanoparticles also reported

Fan, X.; Zhou, Q.; Xia, C.; Cristofoli, W.; Mays, J.; Advincula, R.; "Living Anionic Surface-Initiated Polymerization (LASIP) of Styrene from Clay Nanoparticles Using Surface Bound 1,1-Diphenylethylene (DPE) Initiators", *Langmuir* **2002**; *18*(11); 4511-4518.

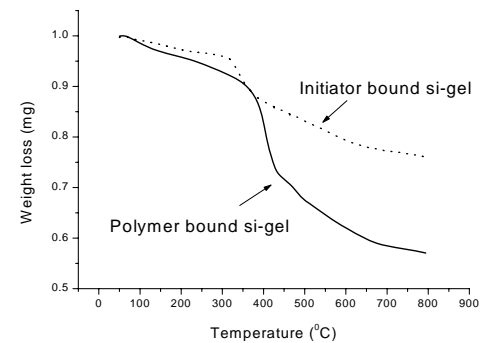



Rigoberto C. Advincula, William J. Brittain,  WILEY-VCH
Kenneth C. Caster, Jürgen Rühle (Eds.)

Polymer Brushes

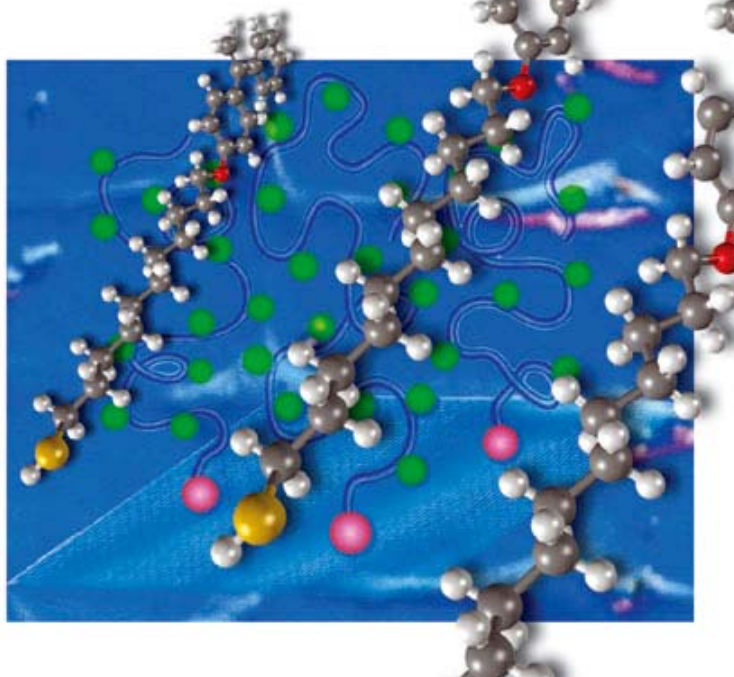

Other SIP Projects of the Advincula Research Group.

- Advincula, R. et.al. *J. Phys. Chem. B.* 2004, *108*, 11672-11679.
- Advincula, R. et.al. *Macro. Rapid Comm.* 2004, *25*, 498-503.
- Advincula, R. et.al. *Langmuir* 2003, *19*, 916-923.
- Advincula, R. et.al. *Langmuir* 2003, *19*, 4381-4389.
- Advincula, R. et.al. *Colloids Surf. A* 2003, *219*, 75-86.
- Advincula, R. et.al. *Langmuir* 2002, *18*, 8672-8684.
- Advincula, R. et.al. *Langmuir* 2002, *18*, 3324-3331.
- Advincula, R. et.al. *Langmuir* 2002, *18*, 4511-4518.
- Advincula, R. et.al. *Chem. Mater.* 2001, *13*, 2465-2467.



Outline of Projects

- ▶ **Project 1.** Electrodeposition and Patterning of Conjugated Polymers Using The Precursor Polymer Approach.
- ▶ **Project 2.** Nanostructured Ultrathin Films of Oligothiophenes and Dyes.
- ▶ **Project 3.** Living Anionic Surface Initiated Polymerization (LASIP) on Nanoparticles
- ▶ **Project 4.** Nanoparticle Synthesis Using Block Copolymer Micelles, Star Copolymers and Polyelectrolyte Complexes
- ▶ **Project 5.** Functional Dendrimers as Organic Nanoparticles
- ▶ **Project 6.** Hybrid Nanoparticle-Dendron Materials: Energy Transfer Phenomena
- **Conclusions**



Project 4

Nanoparticle Synthesis Using Block Copolymer
Micelles, Star Copolymers and Polyelectrolyte
Complexes

NASA (Microgravity): MSFC-NAG8-1678



Project 4a. Nanoparticles Using Star Block Copolymer and Polyelectrolyte Complex with Terthiophene Amphiphile

1. **Silver:** catalysis, photographic processes
2. **CdS:** optoelectronics, photoluminescence
3. **Gold:** optoelectronics, electronics, biosensors
4. **Silica:** insulator, catalyst support, membrane, filling material
5. **Palladium:** catalysis
6. **TiO₂:** photoelectrochemistry
7. **Metal oxide:** Mg, Ca, Mn, Fe, Co, Ni, Cu
8. **Polymer:** conducting composite, drug delivery

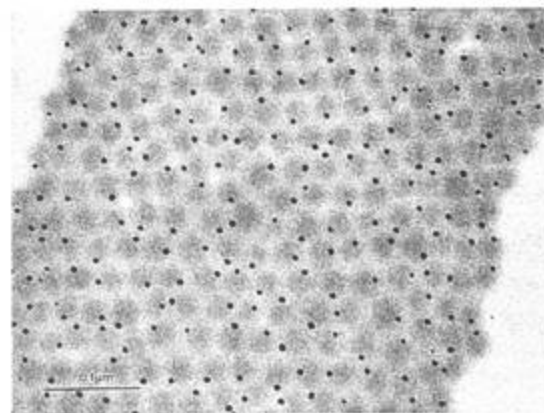

Nanoparticles and nanostructured Films; Fendler, J. H., Ed.; Wiley-VCH; Weinheim, 1998.

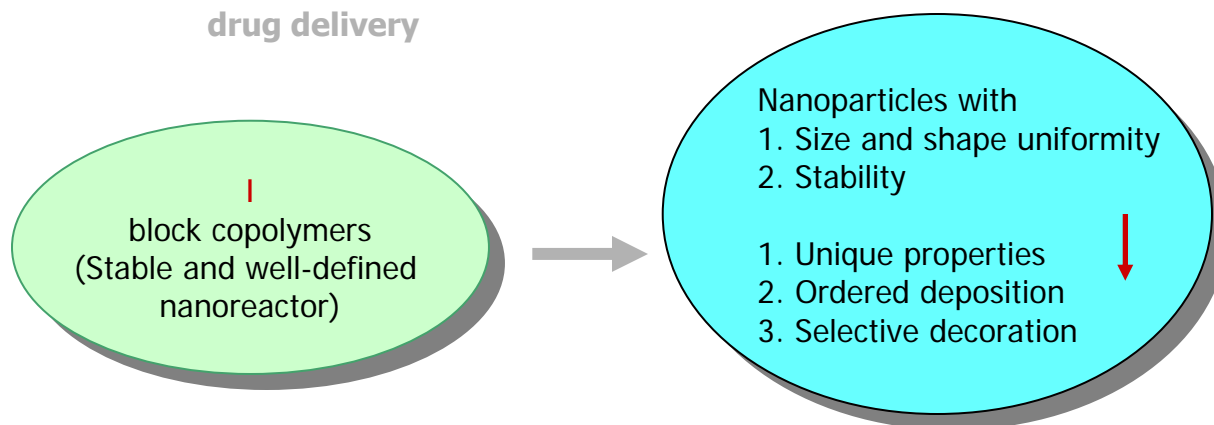



The Concept of Block Copolymers as Nanoreactors

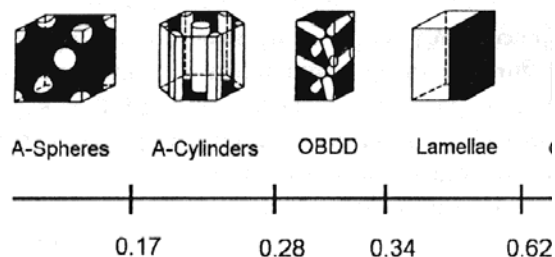

- ◆ **Nanoparticles** as colloidal systems of a solid-state material - dimensions in between molecules and a bulk solid-state material.
- ◆ **Strategies for the synthesis of nanoparticles:** surfactant or polymeric amphiphiles (block copolymers) micelles as a “nanoreactor” for nanoparticle synthesis.
- ◆ **Mechanism** - Metal ions trapped inside the particles exposed to precipitating or reducing agents to start nanoparticle growth: the number of metal ions initially trapped inside the particle determine growth.
- ◆ **Key step:** Control over the diffusion of reagents into the micelle.
- ◆ **Design:** The possibility of attaching coordinating ligands to the polymer in order to stabilize both precursors and nanoparticles within.

- **Strategies for the gold nanoparticle preparation**

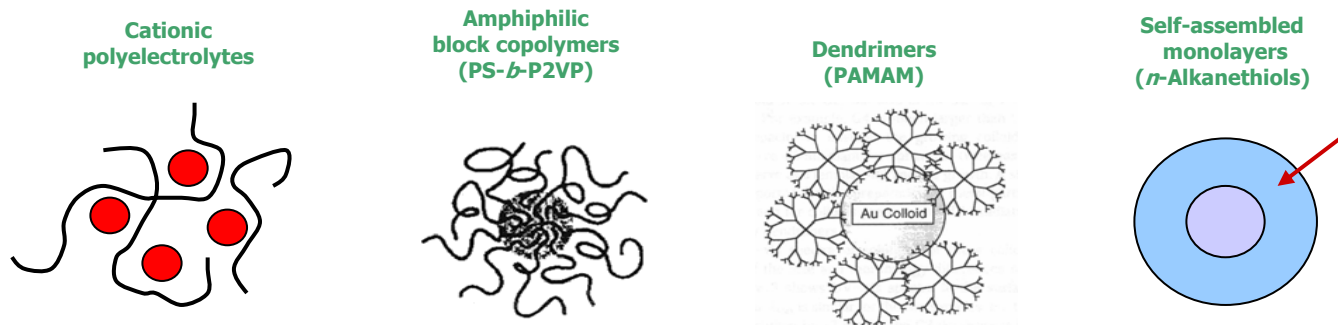

- **“Stable Nanoreactor”** for the control of size and shape of nanoparticles



Synthesis of Nanoparticles in General

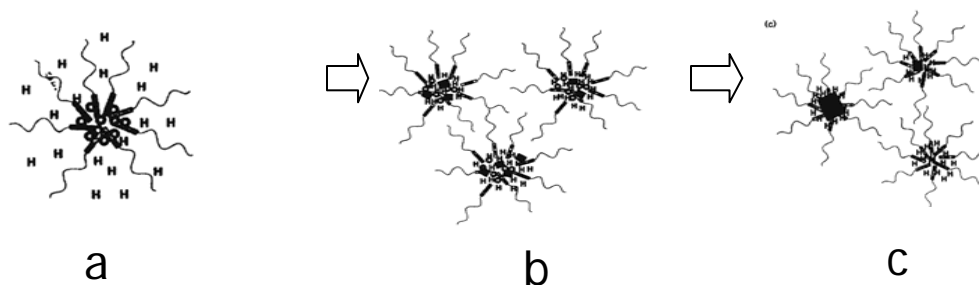

◆ Schematic representation of the concurrent process during reduction reaction inside block copolymer micelles.

- Reduction is initiated by the entry of the reducing agent into the core of the micelles loaded by precursor salt.
- Destabilized micelles exchange block copolymer and may coagulate.
- "Empty" micelles are formed besides block copolymer stabilized gold particles.

H: reduction agent; **O**: precursor salt; crystal.



Star block copolymer (PS-*b*-P2VP)
N: Au = 10:1

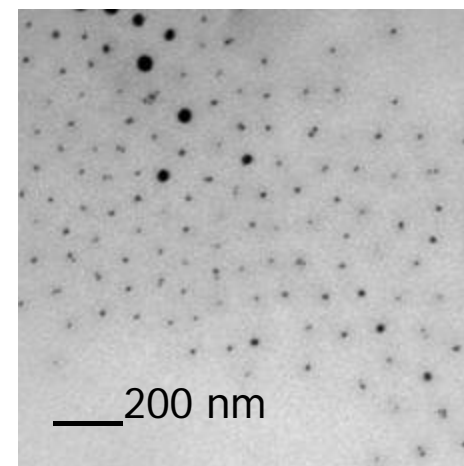
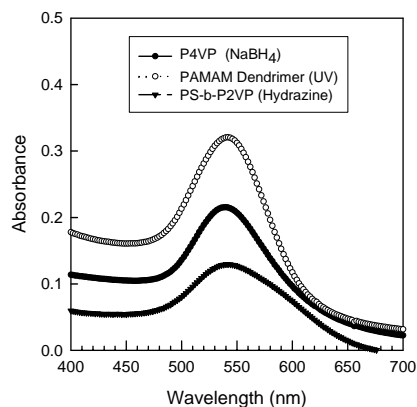



Reduction of Au in Star Copolymers

1. Synthesis of PS-*b*-P2VP

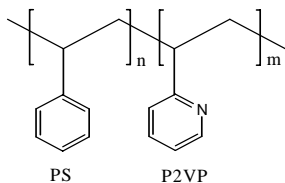

2. Synthesis of Star Block Copolymer

PS-*b*-P2VP + Coupling Agent
(EGDMA)

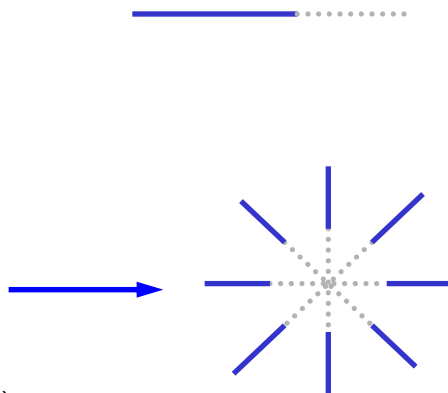
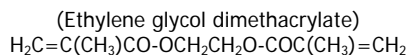

1. Polyionic block

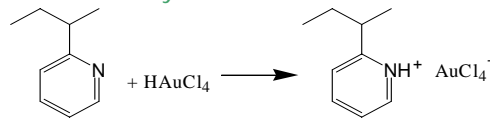

2. Reduction with Hydrazine

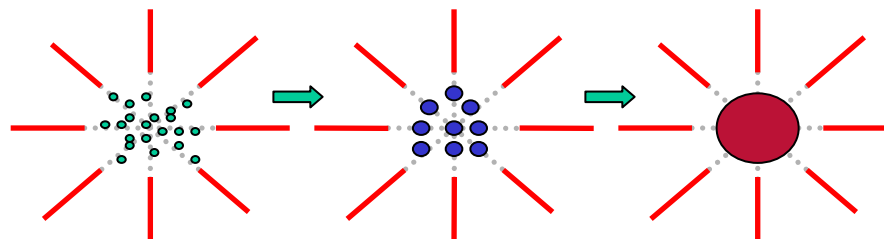
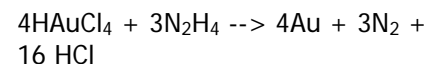

Polyionic star block copolymer

Reduction, Nucleation and Growth

- Synthesis by anionic polymerization, complete characterization necessary
- Stability in solution compared to micelles
- Control of diffusion of salts and reducing agent in organic solvents

Youk, J. H.; Park, M.-K.; Locklin, J.; Advincula, R.; Yang, J.; Mays, J.; "Preparation of Aggregation Stable Gold Nanoparticles Using Star-Block Copolymers", *Langmuir* **2002**; 18(7); 2455-2458.

Youk, J. H.; Yang, J.; Locklin, J.; Park, M.K.; Mays, J.; Advincula, R. "Controlled Preparation of Gold Nanoparticles using Well-defined Star Block Copolymers" *ACS-Polymer Preprints*, **2001** 42, 2, 358.



TEM Characterization of Nanoparticles formed from Star Copolymers

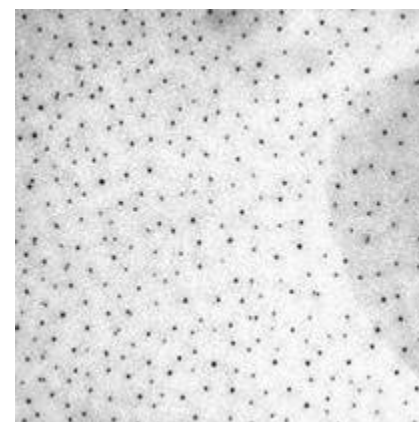
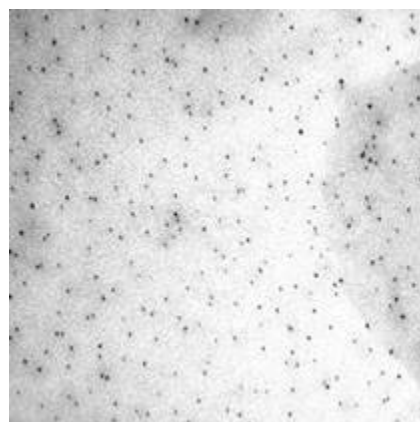
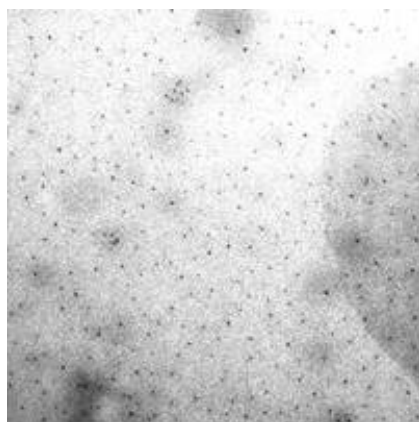

150 nm

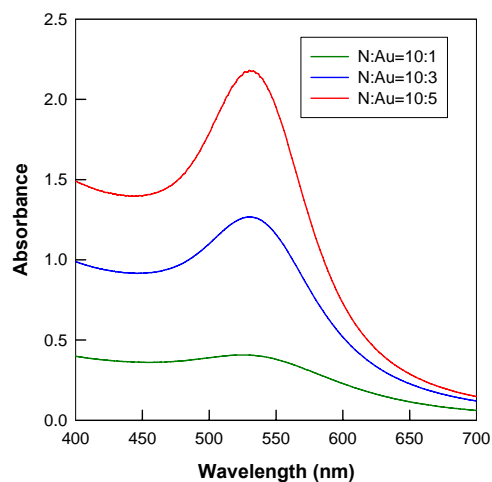

- Controlled size of nanoparticles by controlling ratio of salt and reducing agents
- Very stable compared to micelles even after 1 month
- Control of diffusion of salts and reducing agent in organic solvents
- Good polydispersity
- **Very stable!**



Outline of Projects

- ▶ **Project 1.** Electrodeposition and Patterning of Conjugated Polymers Using The Precursor Polymer Approach.
- ▶ **Project 2.** Nanostructured Ultrathin Films of Oligothiophenes and Dyes.
- ▶ **Project 3.** Living Anionic Surface Initiated Polymerization (LASIP) on Nanoparticles
- ▶ **Project 4.** Nanoparticle Synthesis Using Block Copolymer Micelles, Star Copolymers and Polyelectrolyte Complexes
- ▶ **Project 5.** Functional Dendrimers as Organic Nanoparticles
- ▶ **Project 6.** Hybrid Nanoparticle-Dendron Materials: Energy Transfer Phenomena
- **Conclusions**



Project 5

Nanostructured Ultrathin Films and Functional Dendrimers

ACS-PRF: 35036-G7



Project 5a. Photoalignment and Synthesis of *All*-Azobenzene Functionalized Dendrimers

- **Dendrimers as optical Nanoparticles**
- Anisotropic changes by photoisomerization on globular shape of dendrimer
- changes in the refractive index, dielectric constants

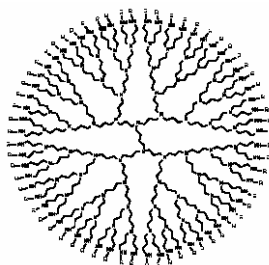

Synthesis
Matrix studies
Photoisomerization

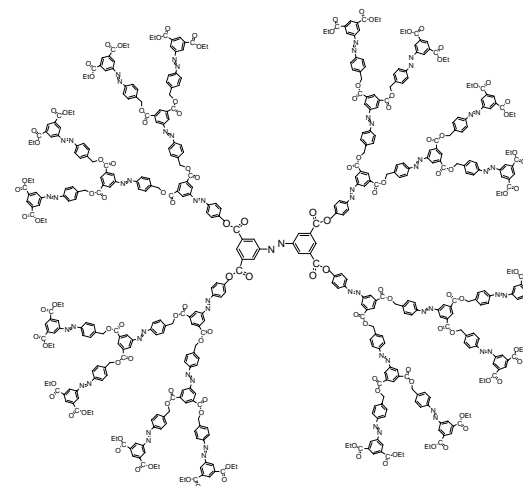
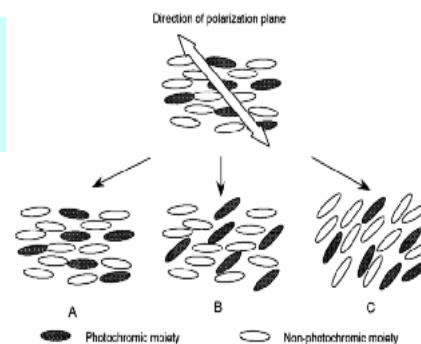
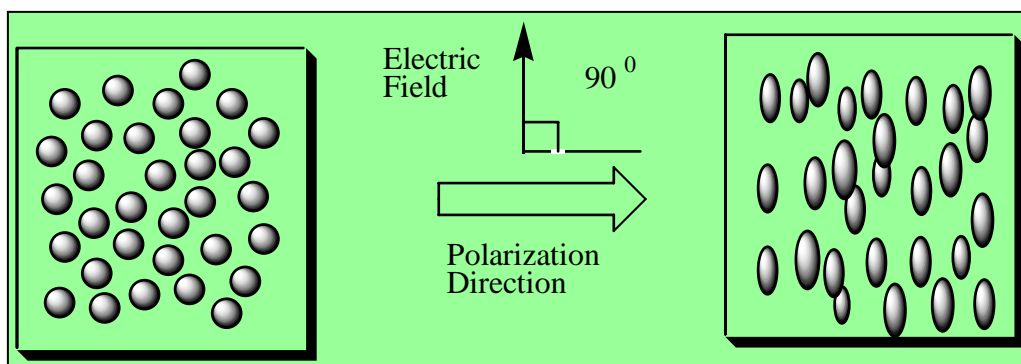

Organic Letters. S. Wang, R. Advincula, "Design and Synthesis of Photo-responsive Poly(benzyl ester) Dendrimers with *All*-azobenzene repeating units"- ASAP



Synthesis of Azobenzene-functionalized PAMAM Dendrimers

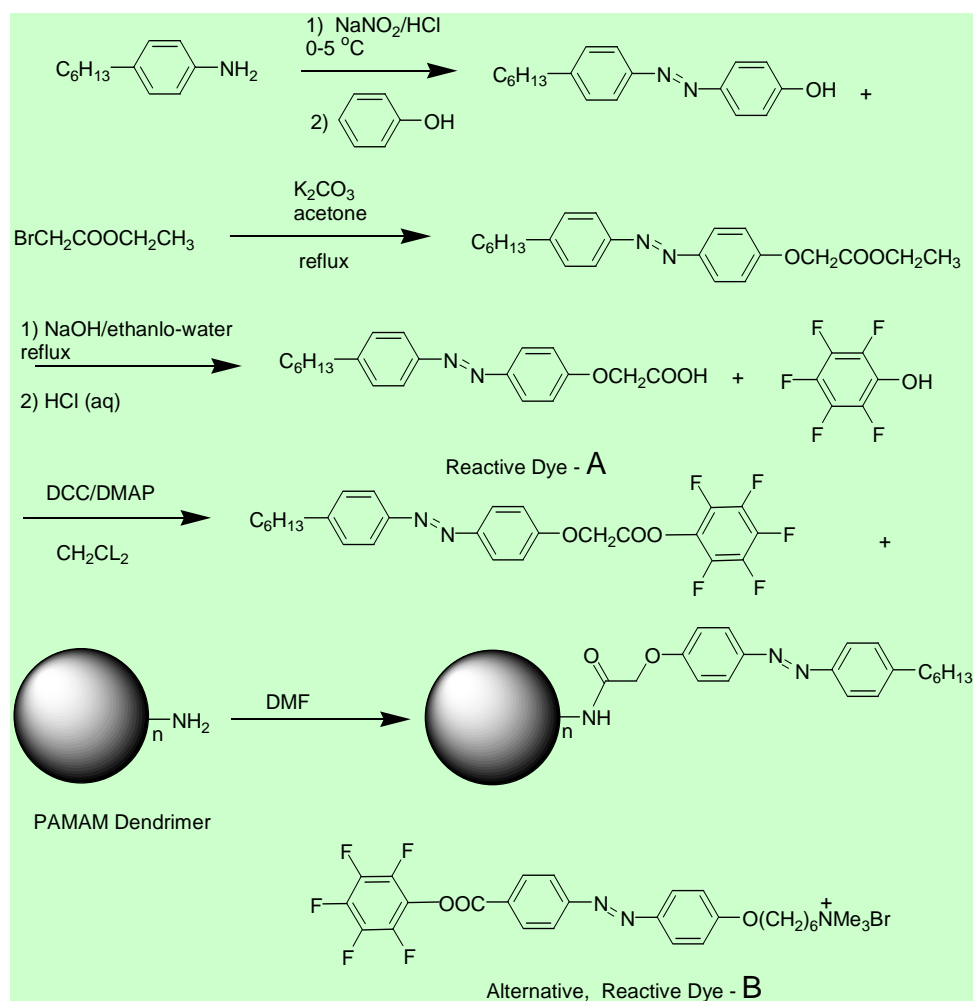

PAMAM-P-32A

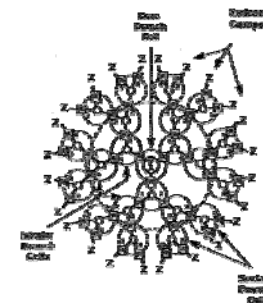
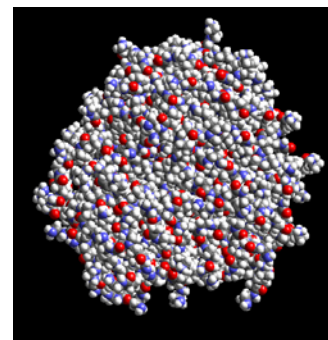

Wang, S.; Park, M.; Advincula, R. Synthesis strategies and photoalignment of azobenzene functionalized dendrimers: Nanostructured ultrathin films and application Strategies, *PMSE Preprints*, 84, 236, 2001.



Photoisomerization and Photoalignment Studies on LB-Monolayer

- Studies on Perimeter-Functionalized Dendrimers
- Monolayer prepared by LB Deposition on quartz

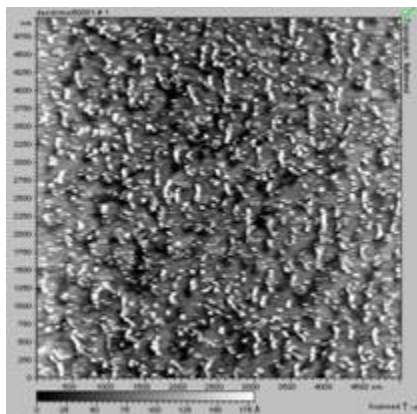

- Deposition at 50 mN/m (high S.P.), molecular area of 620 \AA^2
- UV-vis spectra under UV light irradiation.
- As *trans-to-cis* photoisomerization proceeds, $\pi-\pi^*$ band peak about 338 nm decreases, and $n-\pi^*$ absorption band at 440 nm increases.

PAMAM-P-32A

Photoisomerization

Photoalignment

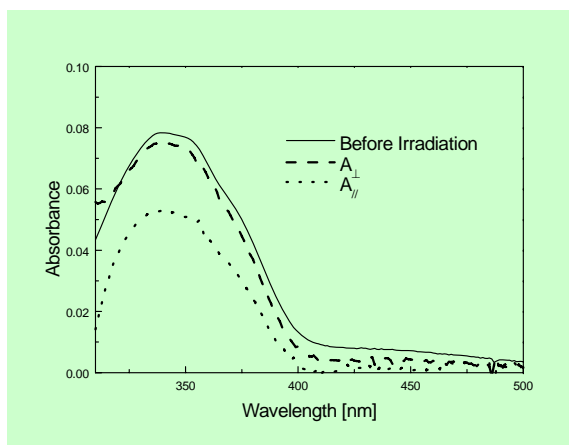
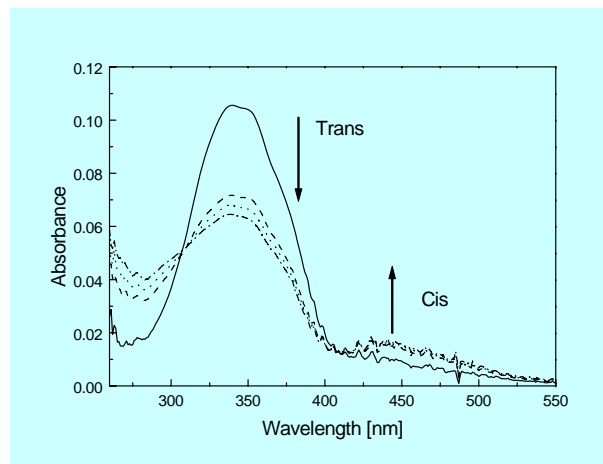

Polarized UV light ($> 340 \text{ nm}$). A *high dichroism* - at various irradiation times (up to $A_{(90)}/A_{(0)} = 1.45$)

E-form, major component - visible light for the $n-\pi^*$ transition.



Bulk Photoisomerization and Photoalignment of PAMAM Dendrimers

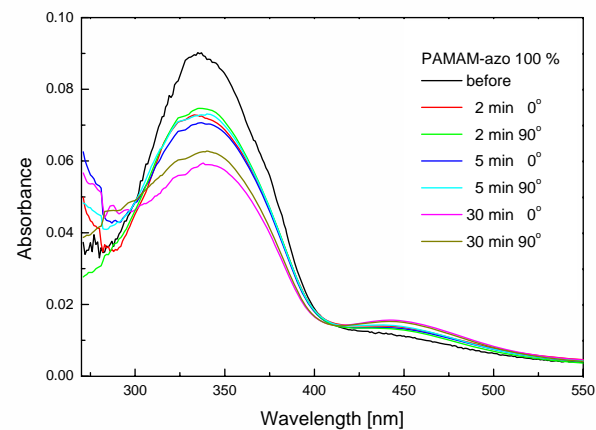
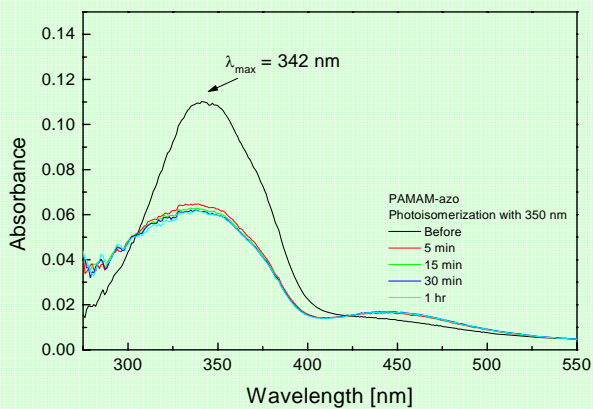
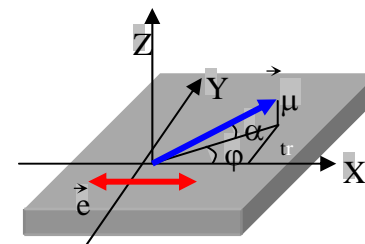
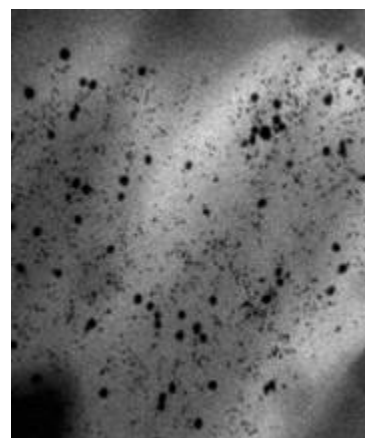
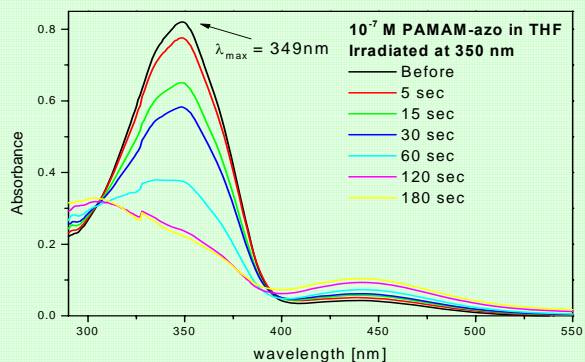

Advincula, R.*; Patton, D.; Park, M.-K.; Wang, S. "Evanescent Waveguide and Photochemical Characterization of Azobenzene Functionalized Dendrimer Ultrathin Films" *Langmuir* **2002**, *18*, 1688-1694.



Attenuated Total Reflection Spectroscopy: Waveguide Experiments

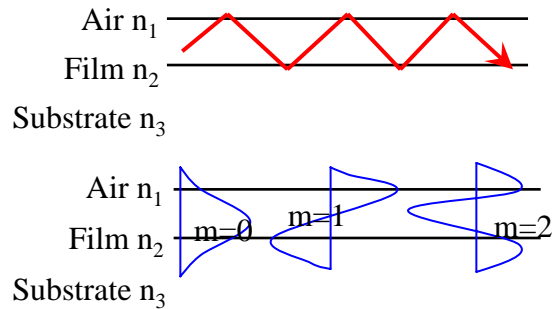
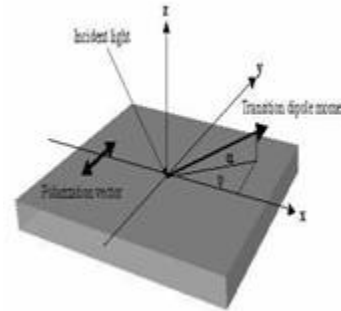
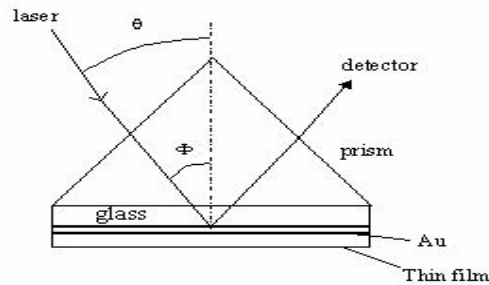

$$\beta_0 + \beta_1 + m\pi = k_z d$$

β_0, β_1 = phase shifts
 m = mode order
 k_z = wave vector
 d = thickness

\mathbf{y} : the direction of polarized light
 $\mathbf{n}_x, \mathbf{n}_z$ are calculated by TM-mode (p-wave)
 n_y is calculated by TE-mode (s-wave)

- Guided optical waves – waveguide modes (reflectivity as a function of angle θ_c)
- Kretschman configuration
- Total internal reflection where $n_1 < n_2$ and $n_3 > n_2$ for waveguide layer (n_2 and thickness, d), n_3 , substrate, n_1 , air.



Evanescent Waveguide Results

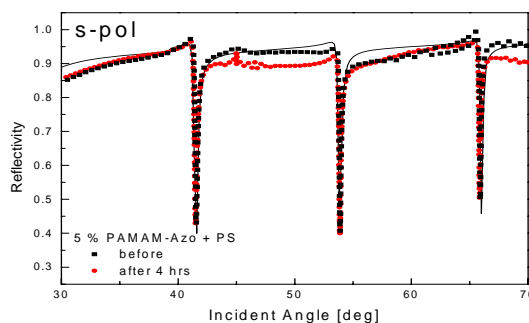
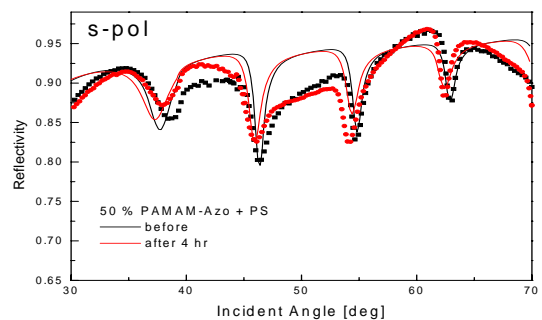
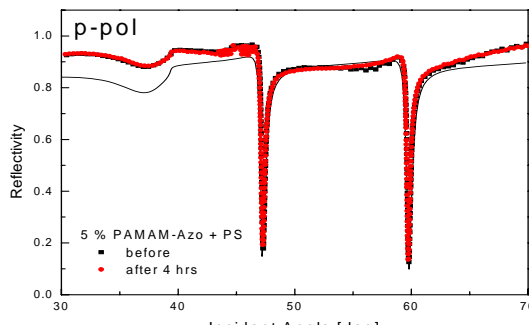
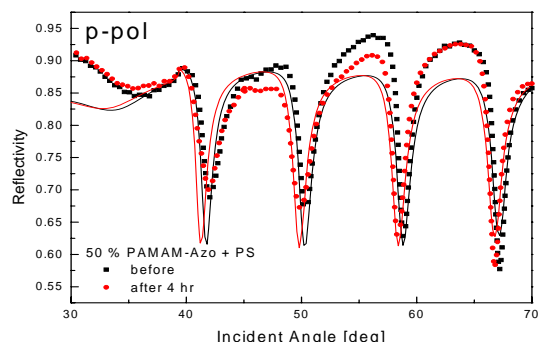

50 % PAMAM-azo + PS

The n_y (same direction with polarization) is decreasing as the irradiation time increases. The n_x does not change much, but n_z (perpendicular to polarization) is decreasing. This result supports the photoalignment result (decreasing of A_{90}).

Little birefringence ($n_x - n_y$) observed which is also consistent with photoalignment results.

R. Advincula, D. Patton, M.K. Park, S. Wang
 "Evanescent Waveguide and Photochemical
 Characterization of Azobenzene Functionalized
 Dendrimer Ultrathin Films"-
Langmuir **2002** 18(5),1688-1694.

50% PAMAM-azo						
Polarization	Irradiation Time	n_x	n_y	n_z	$n_x - n_y$	Thickness
TM (p-wave)	0 hr	1.5047		1.5000	0	2596 nm
	4 hrs	1.5040		1.4900		
TE (s-wave)	0 hr		1.5047		0.0033	
	4 hrs		1.5007			



Total Dendrimer Synthesis

Two main approaches: Convergent and Divergent

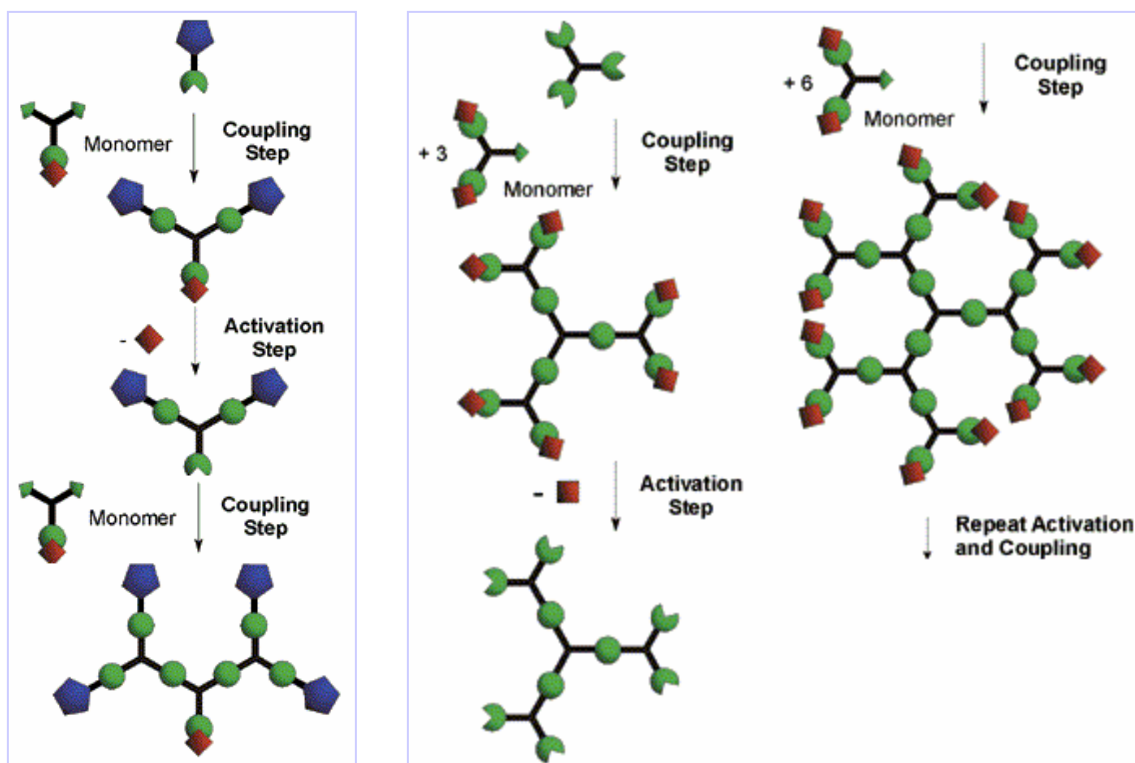

Jean M. J. Fréchet* *Chem. Rev.* 2001, 101, 3819



Project 5b. Total Convergent Synthesis of an *All*-azo-benzene dendrimer

Target dendrimer molecule

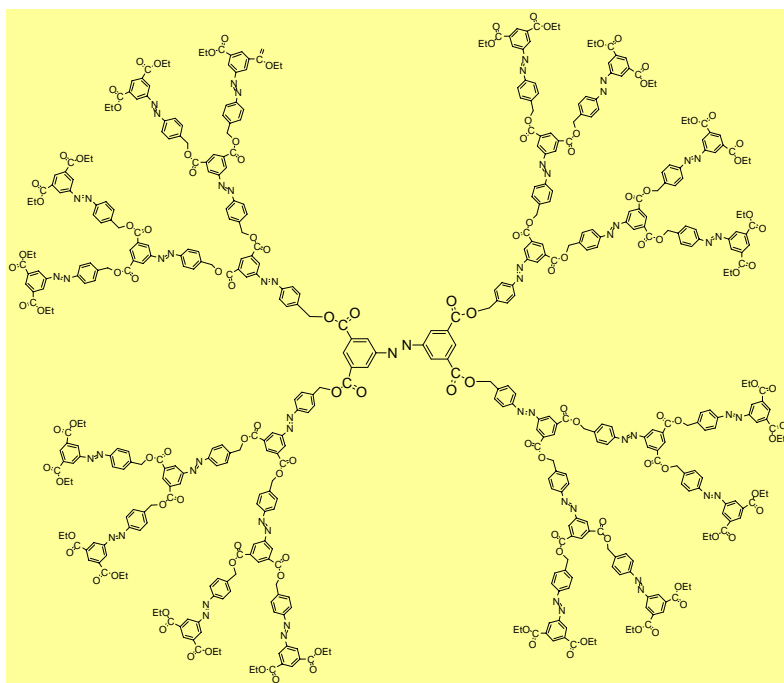

-The dendrimer is constructed by photo-sensitive azobenzene groups
- The azobenzene groups are linked through benzyl ester bonds.

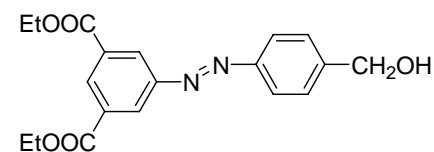

G-1-OH

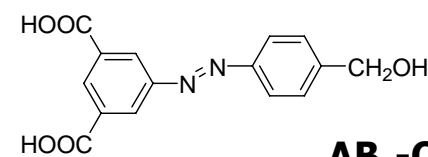

AB₂-OH

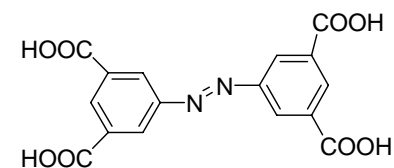

AB₄

- **Target Molecule:** generational control of azobenzene groups
- **Intelligent molecule:** molecular shape and size could be changed upon irradiation by UV light
- **Controlled** azobenzene group density, a “**macrodyer**”- quantifiable absorbing species
- **Controlled aggregates** or “particulate chromophores” a **nanoparticle**
- **Globular shape change** and translational movement within the matrix (environment)

Synthesis: best route!

- Due to synthesis difficulties ... design a new AB₂ monomer for generation growth

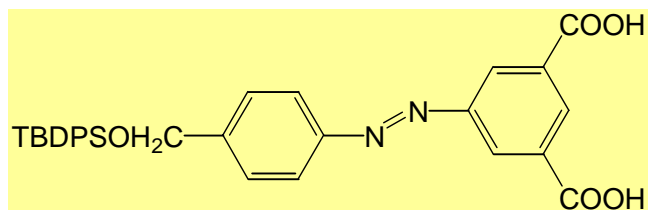

AB₂

-**AB₂ monomer** : two activated carboxylic groups for generation growth and one hydroxymethyl group protected by *tert*-butyldiphenylsilane chloride (TBDPSCI)

-**The protected group TBDPSCI** - easy to remove and Stable towards acidic reaction conditions (acetic acid)

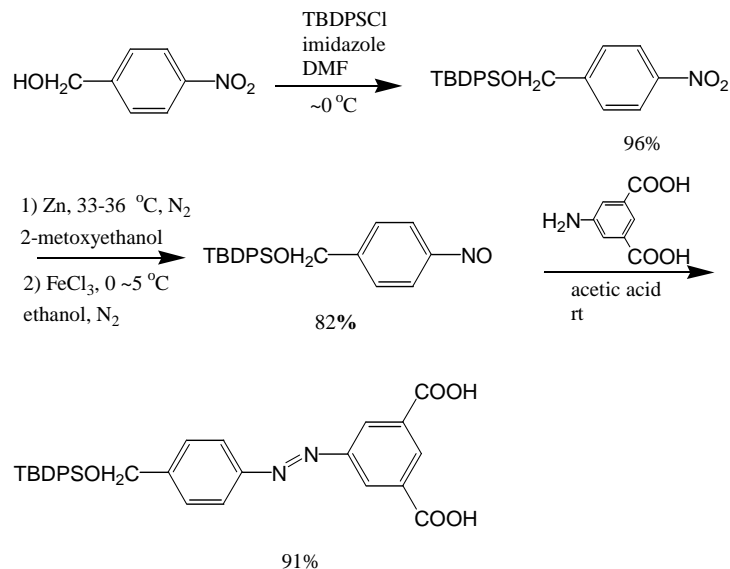

- do nitroso coupling-condensation with aniline
- Higher yields and reproducible towards convergent approach
- **Generation growth:** Esterification with benzyl alcohol (DCC/DMAP) and deprotect, repeat ...



Example: Synthesis of G-4-OH

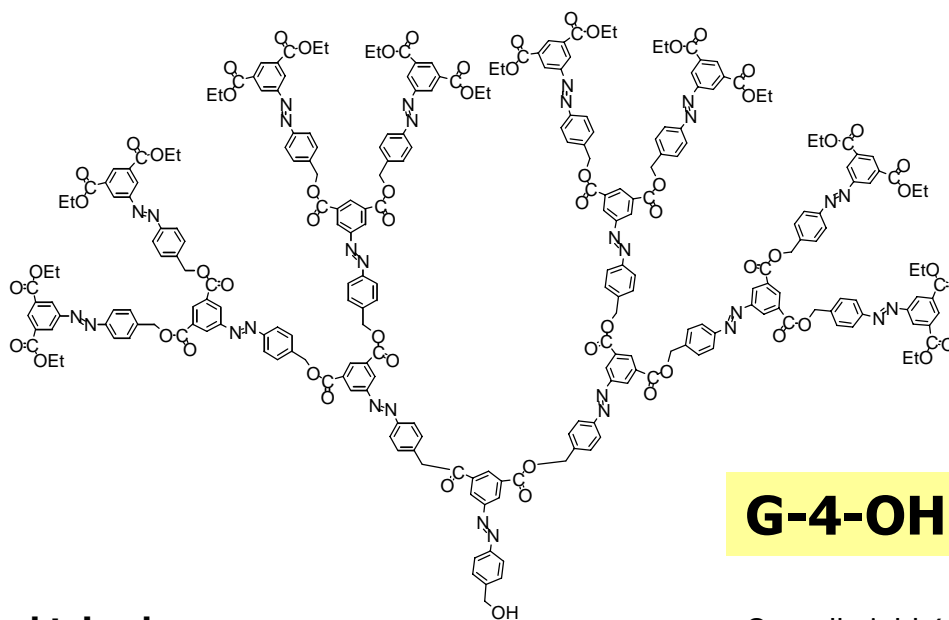

MALDI-TOF-MS: [M + K] 4723.1
(calcd. for C₂₅₇H₂₁₆N₃₀O₆₀, 4684.5).

G-4-OH

Overall yield 64%

The Dendron G-4-OH was easily obtained by coupling G-3-OH with AB₂ monomer, using the same coupling reaction condition, in presence of DCC/DPTS, followed by de-protection with HF-pyridine in overall 64% yield.



All- azobenzene Dendrimer Shape Anisotropic "Organic Nanoparticle"

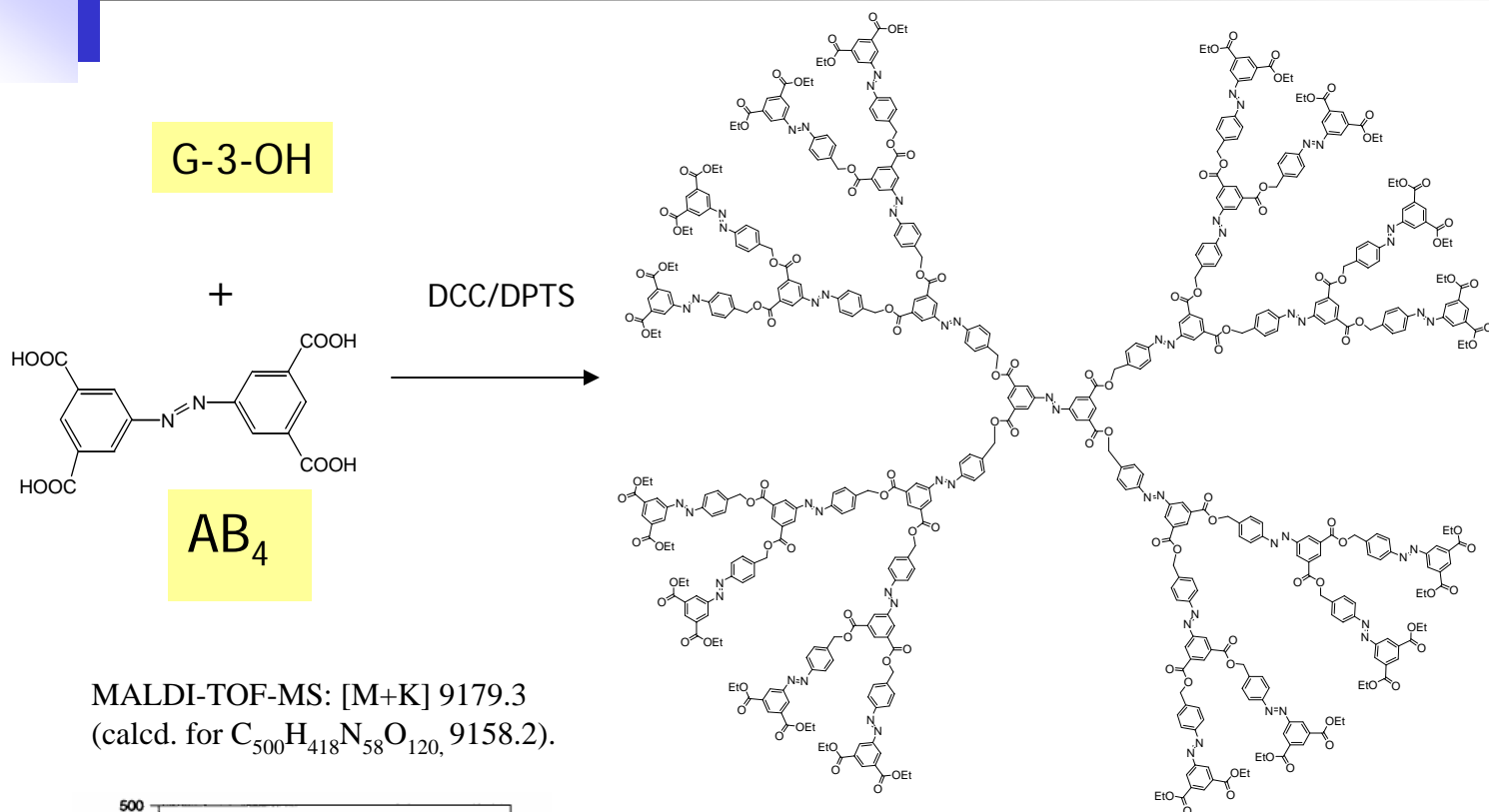

MALDI-TOF-MS: [M+K] 9179.3
(calcd. for C₅₀₀H₄₁₈N₅₈O₁₂₀, 9158.2).

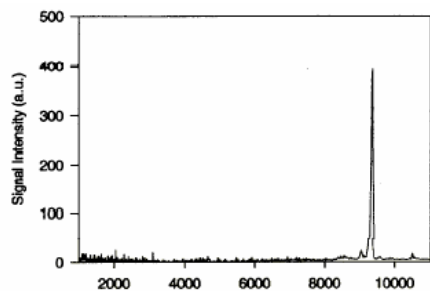

The first example of photo-responsive *all*-azobenzene dendrimers bearing up to 29 azobenzene groups for 4 generations were prepared by a convergent approach...

Wang, S. and Advincula, R. "Design and Synthesis of Photoresponsive Poly(benzyl ester) Dendrimers with all-Azobenzene Repeating Units,
Organic Letters; **2001**, 3(24), 3831-3834.



π -Conjugated Dendrimers

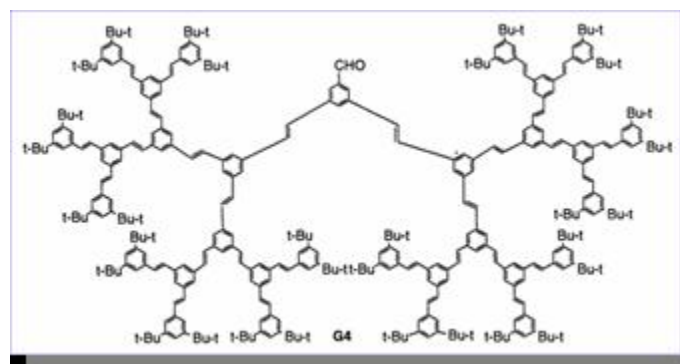
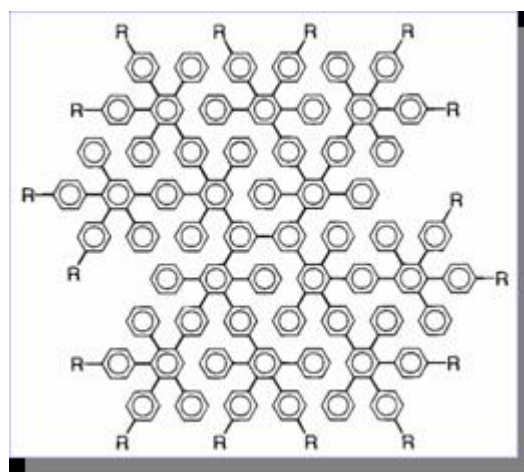
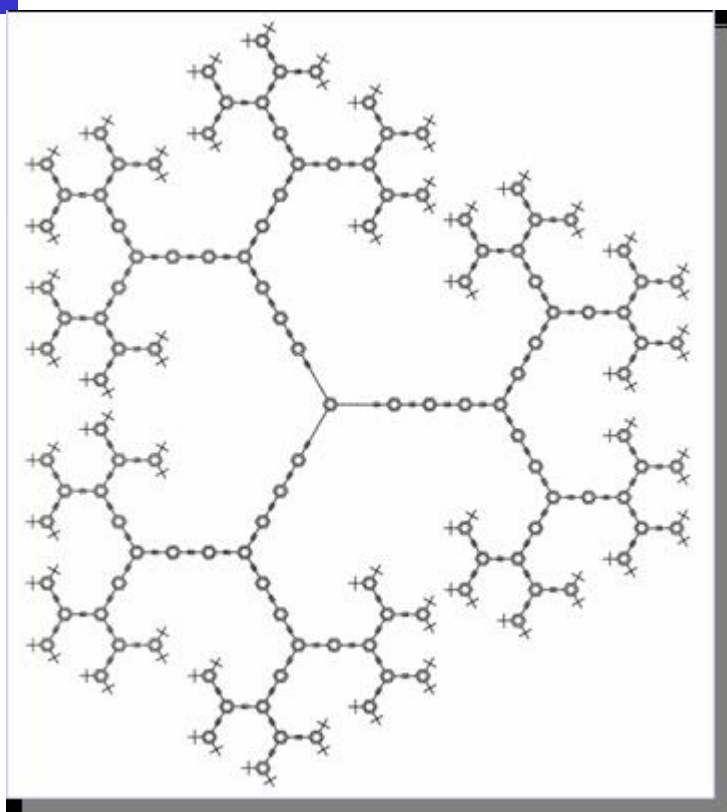

Luping Yu* *JACS* **1997**, *119*, 9079
Klaus Müllen* *Chem. Rev.* **1999**, *99*, 1747
Jeffrey S. Moore* *Acc. Chem. Res.* **1997**, *30*, 402

Conjugated dendrimers with rigid structures, such as phenylacetylene, phenylene vinylene, and polyphenylene dendrimers have also been developed in recent years.



Project 5 c. Synthesis and Deposition of Thiophene Dendrimers

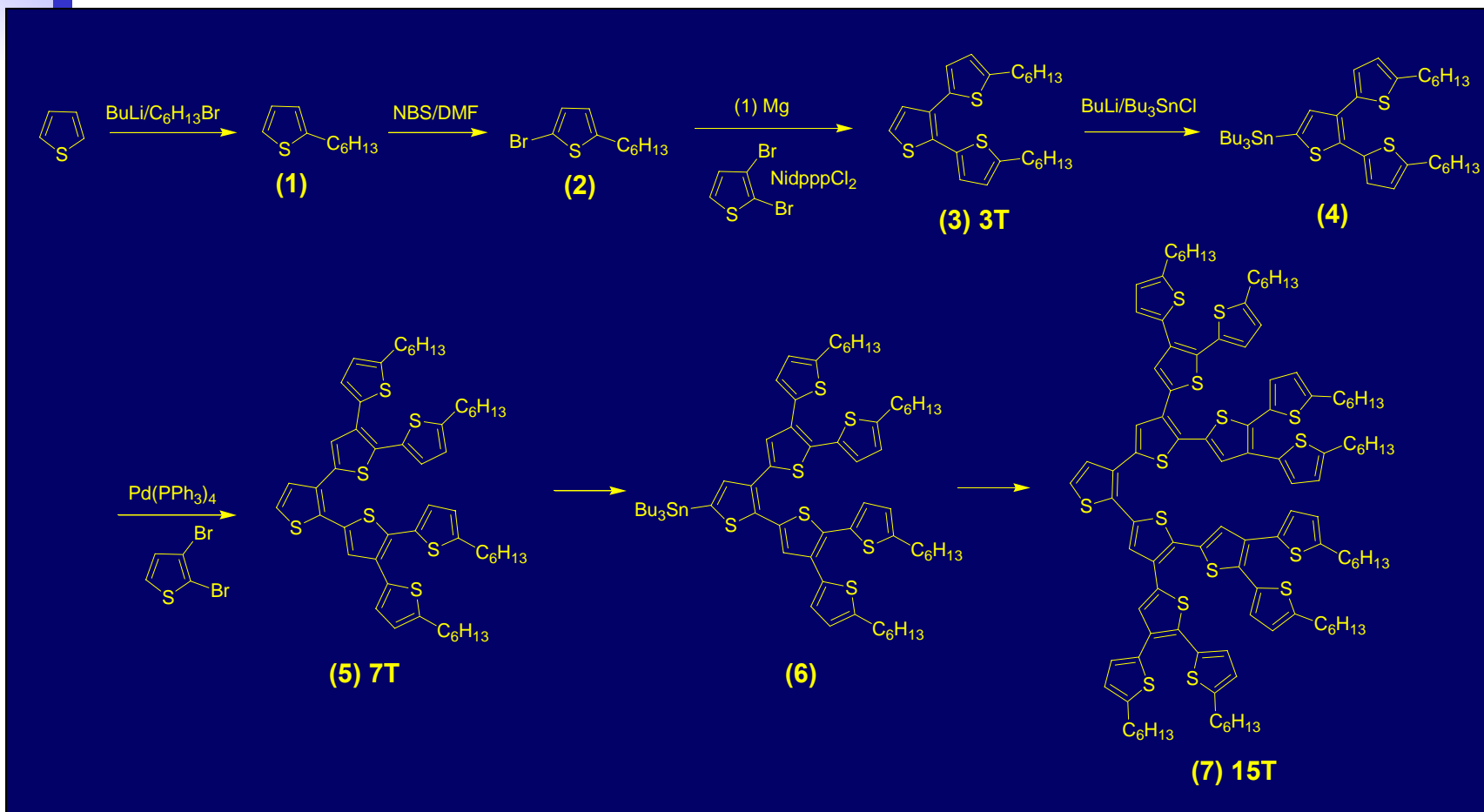

Xia, C.; Fan, X.; Locklin, J.; Advincula, R. C.; "A First Synthesis of Thiophene Dendrimers", *Organic Letters* **2002**; 4(12); 2067-2070.



BuLi/CuCl₂ Coupling to Thiophene Dendrimers

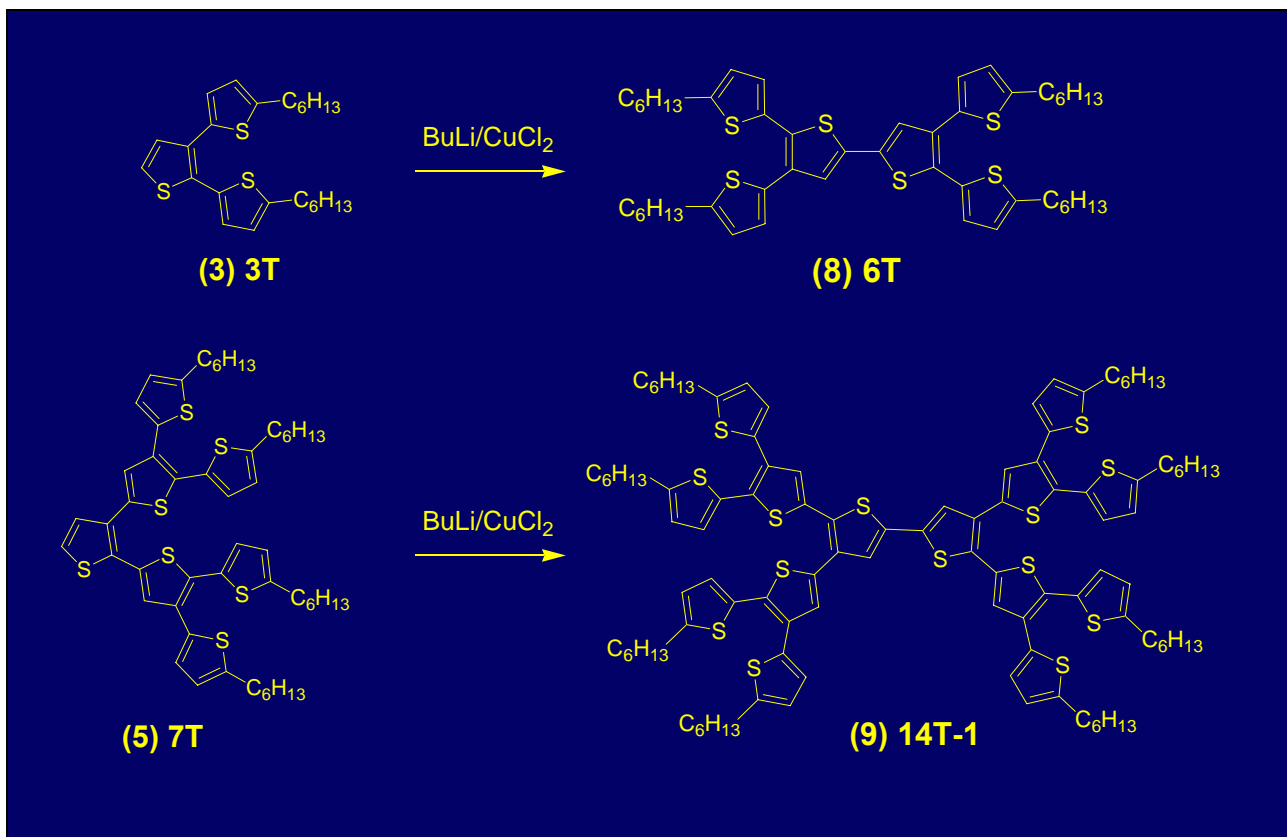



Synthesis of Thiophene Dendrimers

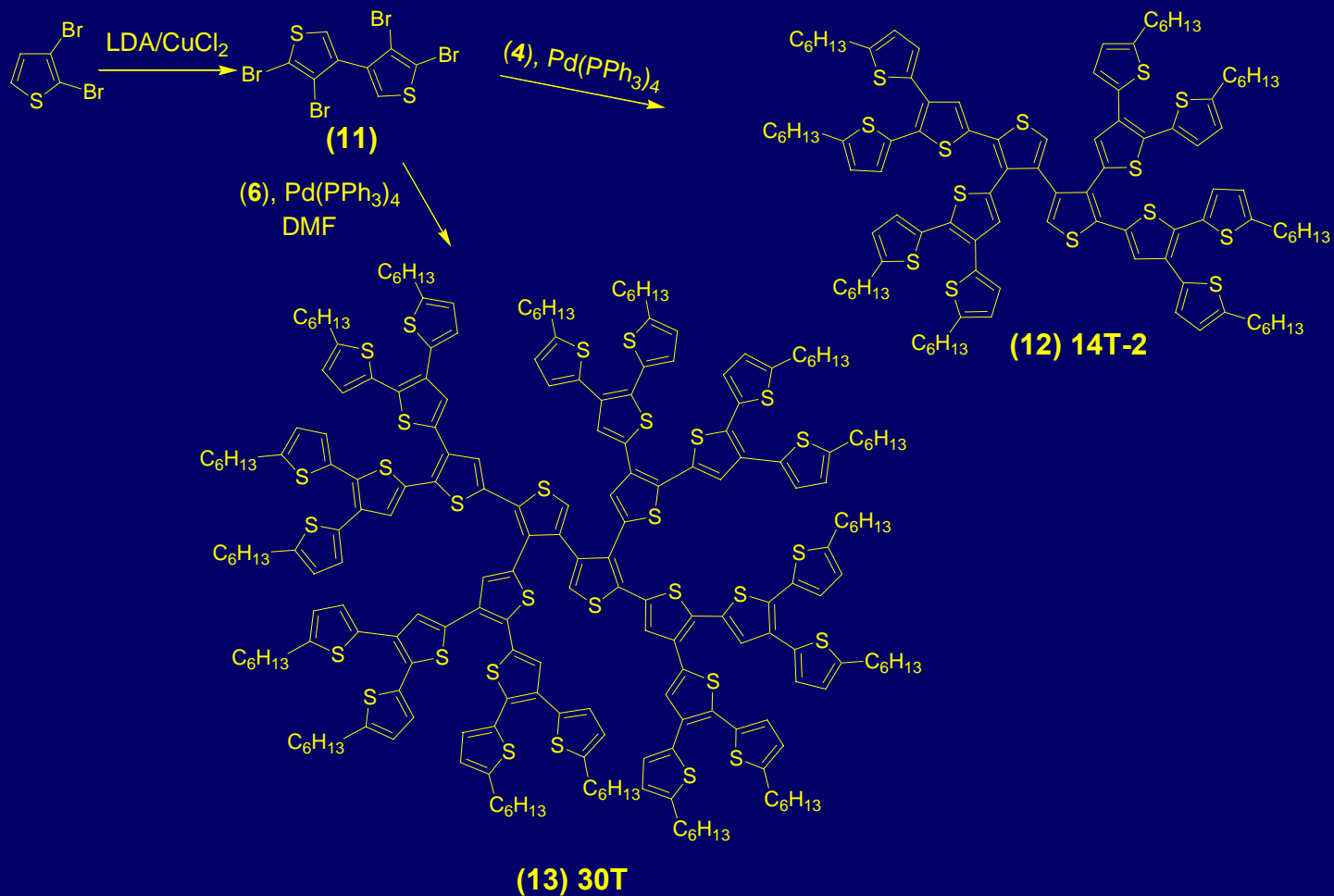



^1H NMR of the Dendrimers

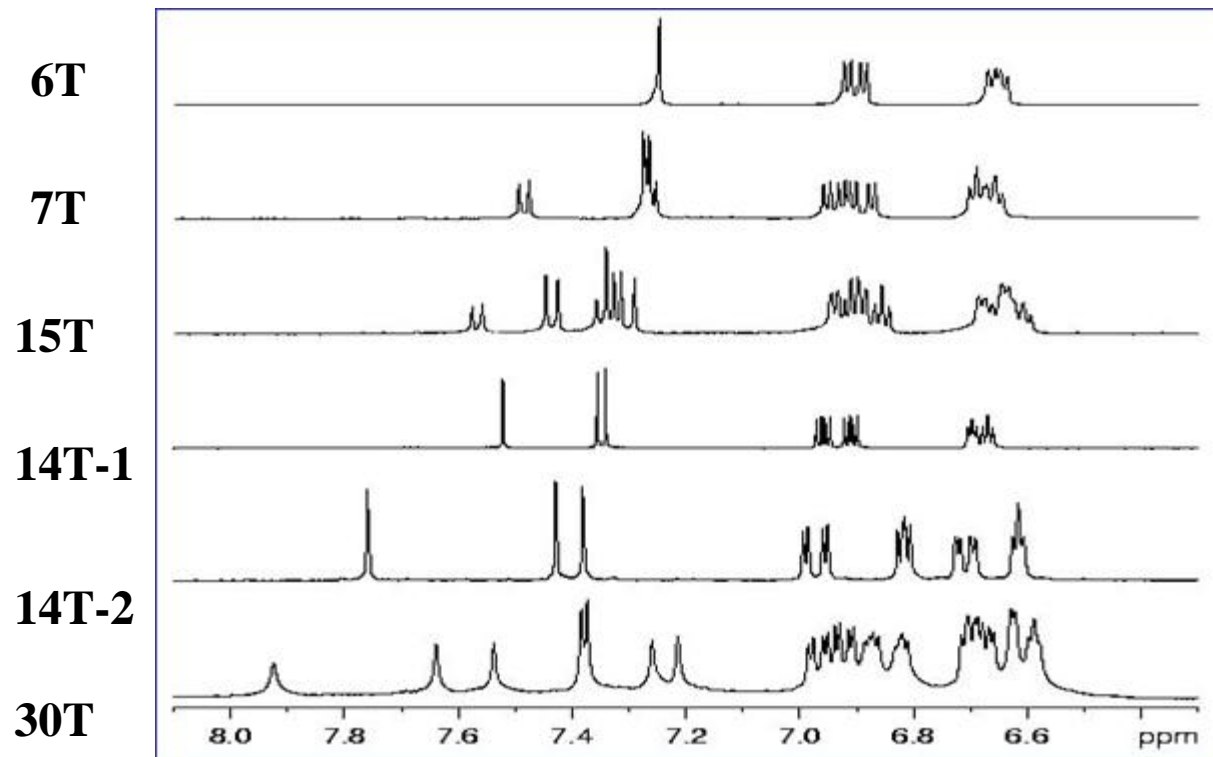

^1H -NMR spectra of **6T**, **7T**, **15T**, **14T-1**, **14T-2**, and **30T** in THF-*d*₈ at 290K. For **6T**, **14T-1**, **14T-2**, and **30T**, the interior protons on the thiophene ring show singlets downfield; and the exterior protons show doublets upfield. For **7T** and **15T**, two doublets were found for the two protons at the focal thiophene, one at the most down field, and the other hidden in the singlets.



MALDI-TOF-MS Characterization

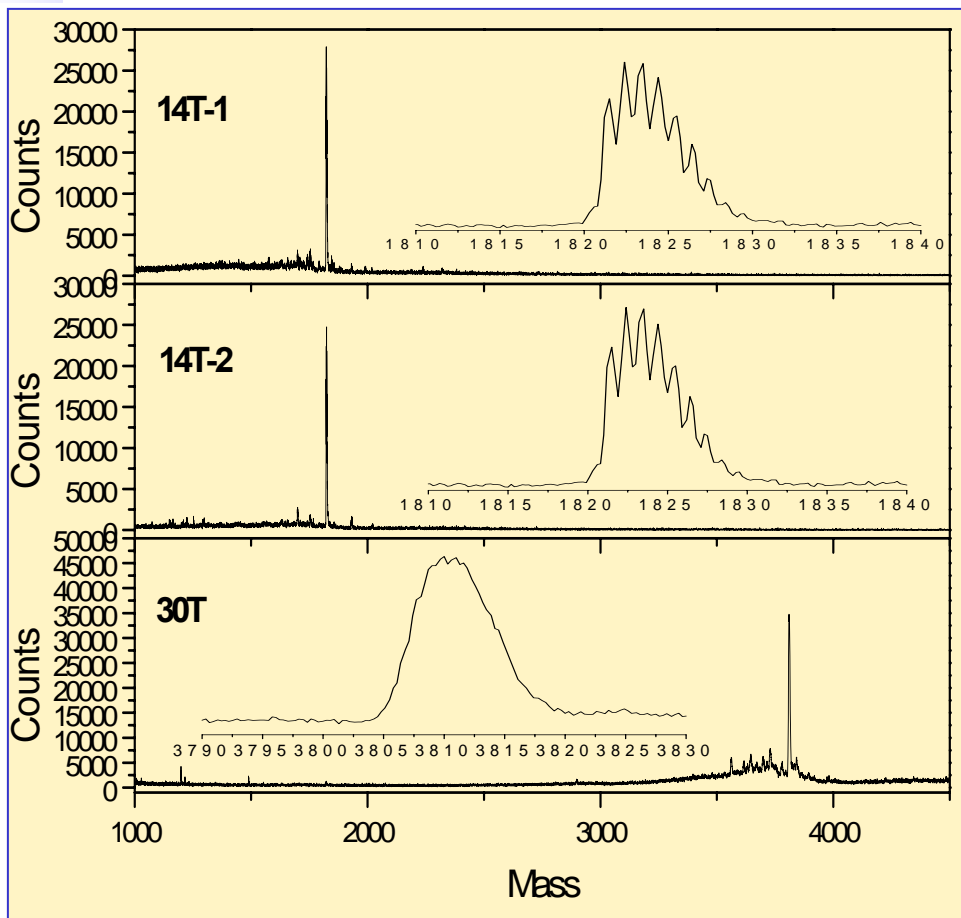

The MALDI-TOF analysis verified monodispersed masses for **14T-1**, **14T-2**, **15T**, and **30T** giving: 1824.0, 1823.6, 1905.3, and 3809.5, respectively. These are consistent with the calculated values: 1823.6, 1823.6, 1905.6, and 3809.2.



Size Exclusion Chromatography

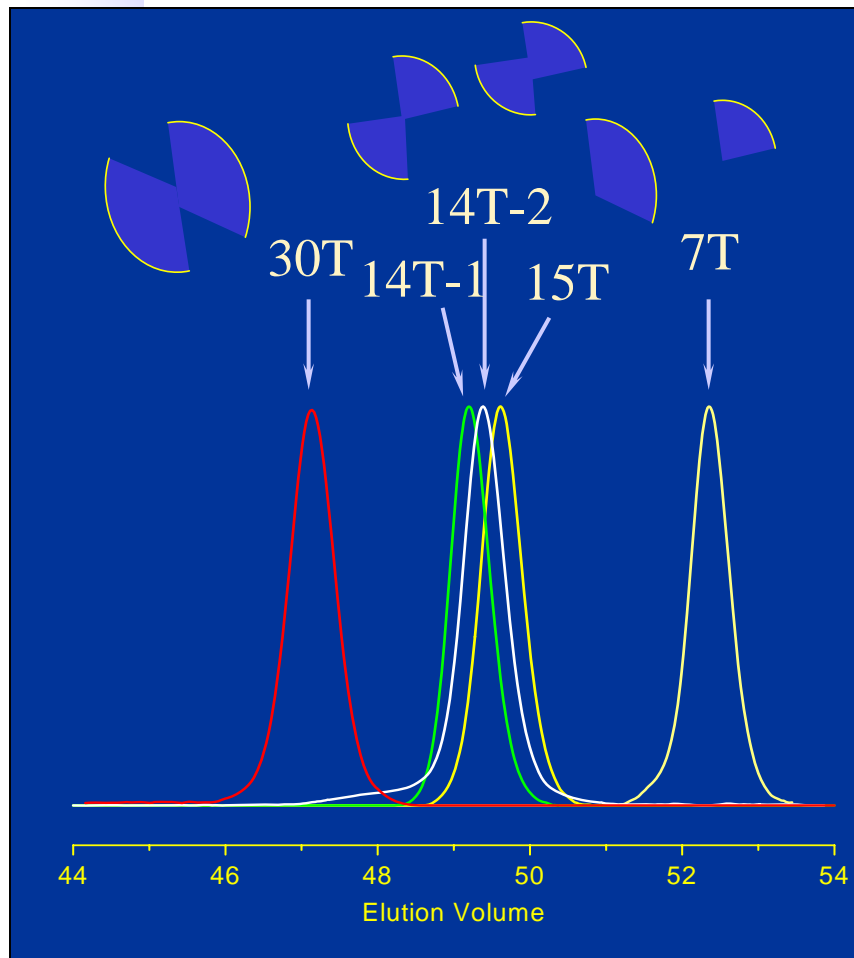

	Mass	MALDI	Mn	DPI
7T	913.5	—	989.7	1.007
14T-1	1823.6	1824.0	1955.1	1.004
14T-2	1823.6	1823.6	1903.6	1.001
15T	1905.6	1905.3	1791.1	1.004
30T	3809.2	3809.5	3202.6	1.005



UV-vis and Photoluminescence

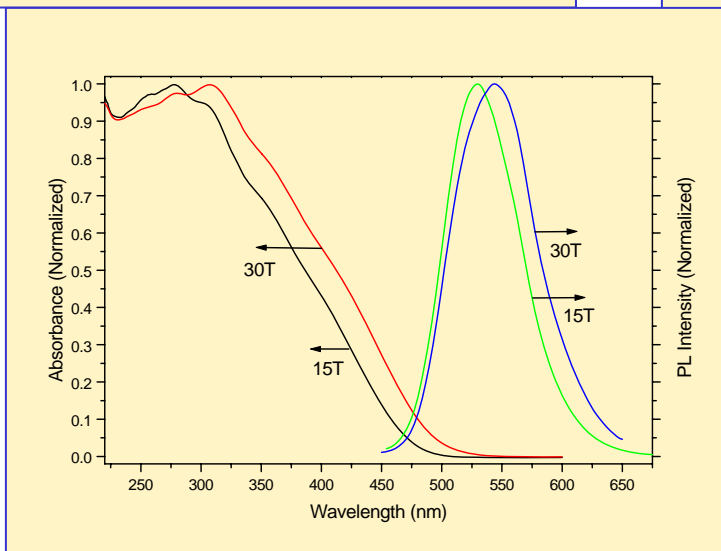
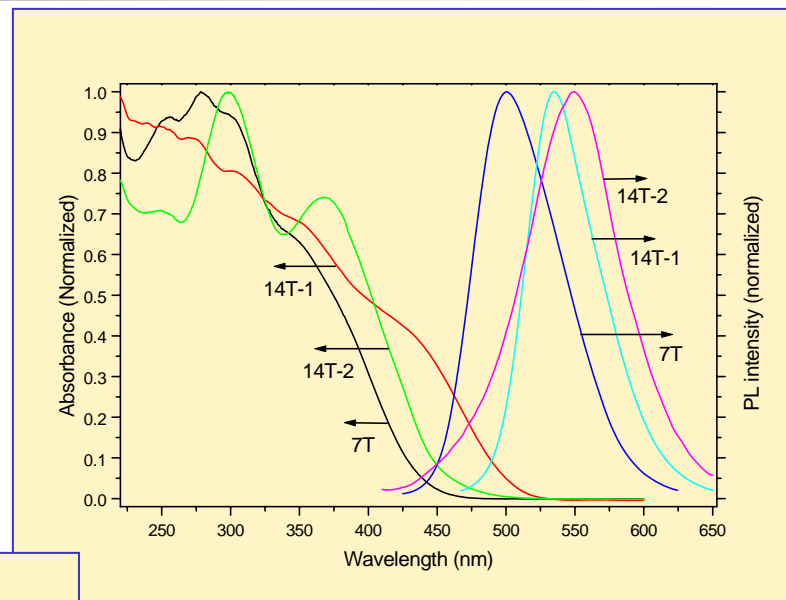
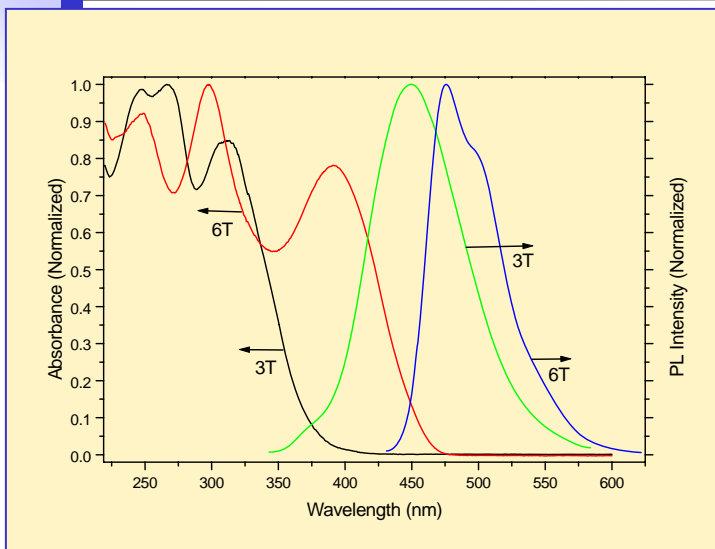

Broad absorption spectra
and finite photoluminescence

Size and configuration
dependence



Summary of Optical and Electrochemical Properties

	Absorption Onset (nm)	PL (nm)	E _g (eV)	E _g (eV) from CV
3T	372	449	3.33	—
6T	458	476	2.71	—
7T	440	500	2.82	—
14T-1	501	534	2.48	2.57
14T-2	454	549	2.73	2.67
15T	473	529	2.62	—
30T	497	543	2.50	2.54

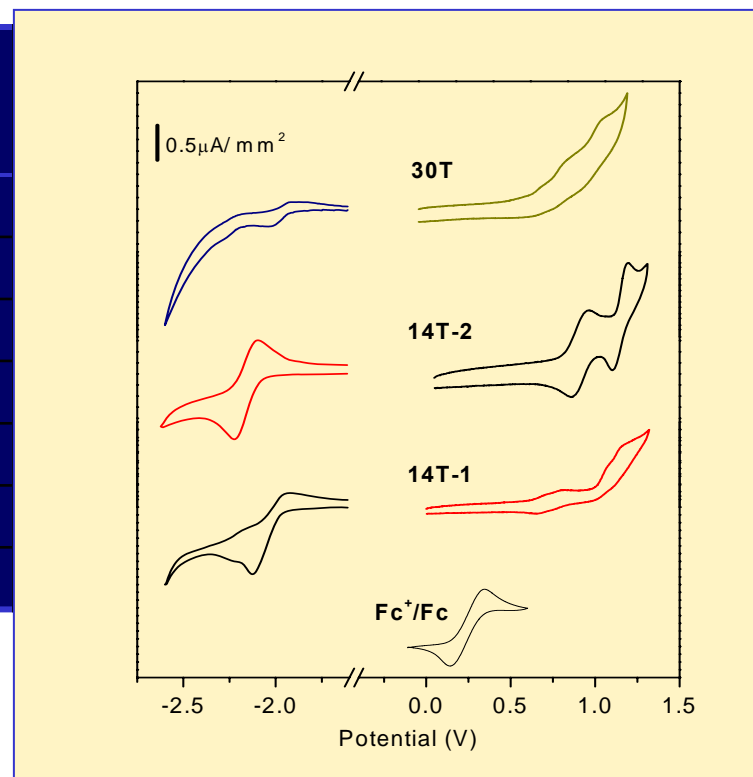

Xia, C.; Advincula, R.*; Locklin, J.; Giess, A.; Nonidez, W. "Characterization, Supramolecular Assembly, and Nanostructures of Thiophene Dendrimers" *J. Am. Chem. Soc.* **2004**, *126*, 8735-8743.



Nanoparticle Aggregates on Mica: 14 T-1

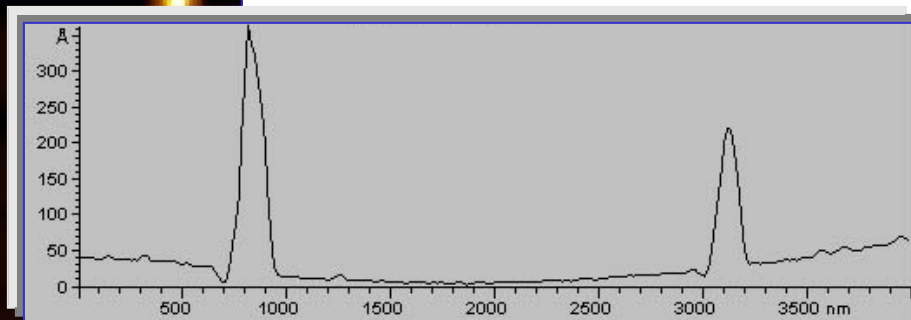
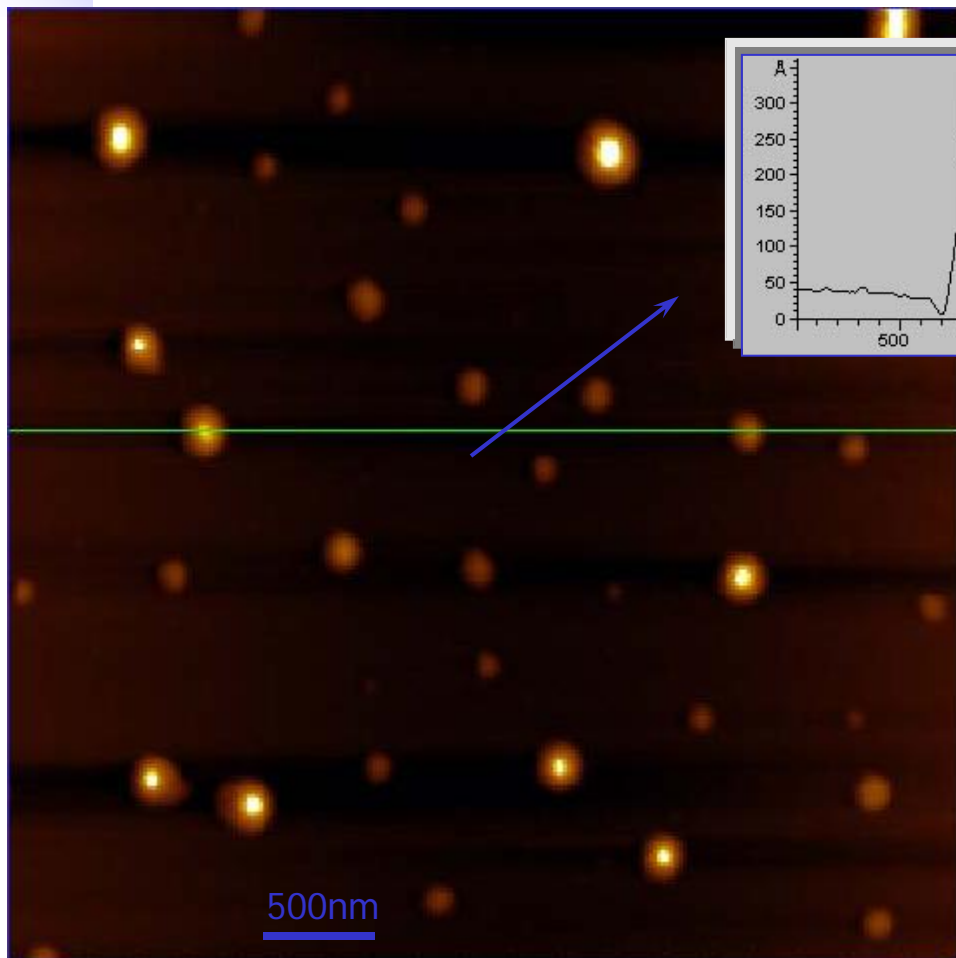

14T-1, drop casted from
1.1 μM solution in THF after
slow evaporation

Globular aggregates formed
with different sizes



Nanoparticle Aggregates on Mica: 30T

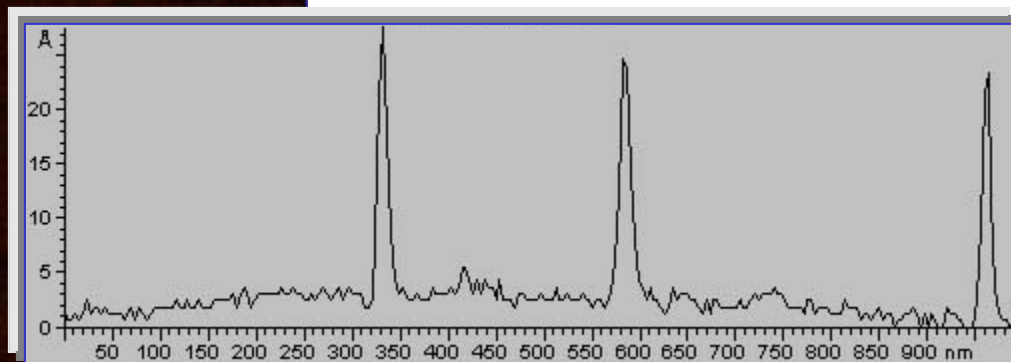
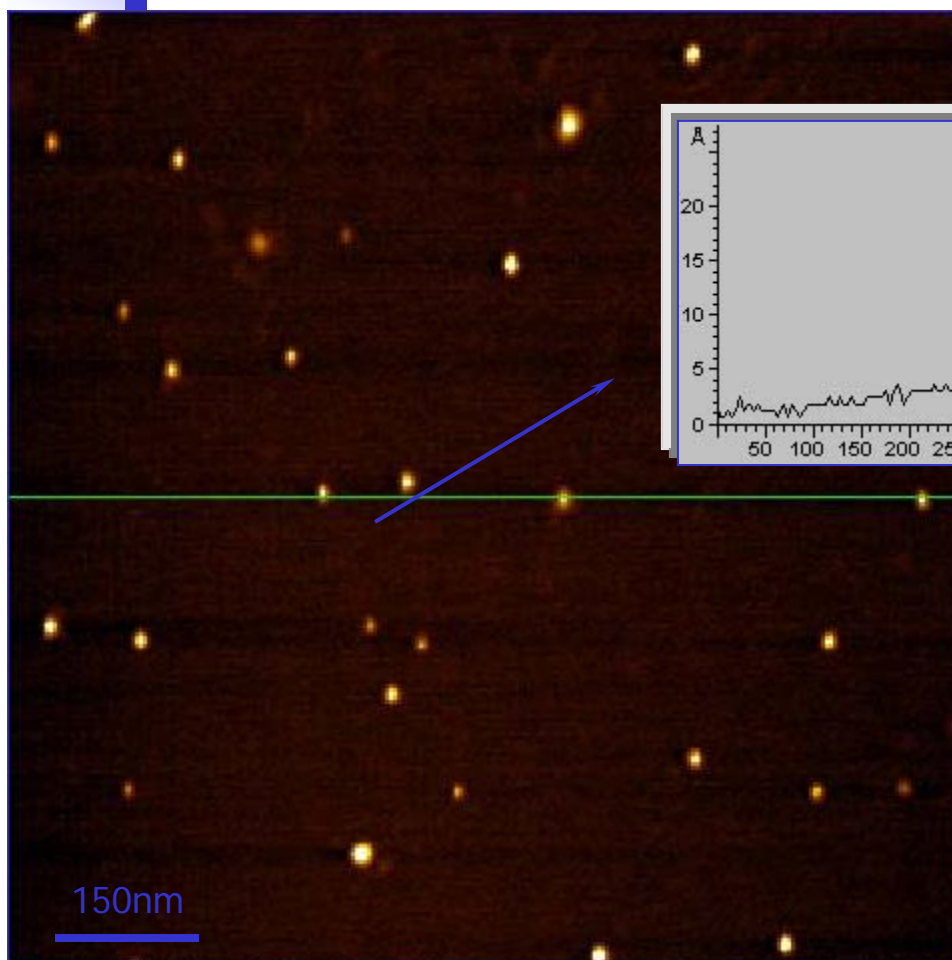

30T, drop casted from
0.58 μM solution in THF after
slow evaporation

Small aggregates or individual
molecules



Nanoparticle Self-Assembly of 30T on Graphite (HOPG)

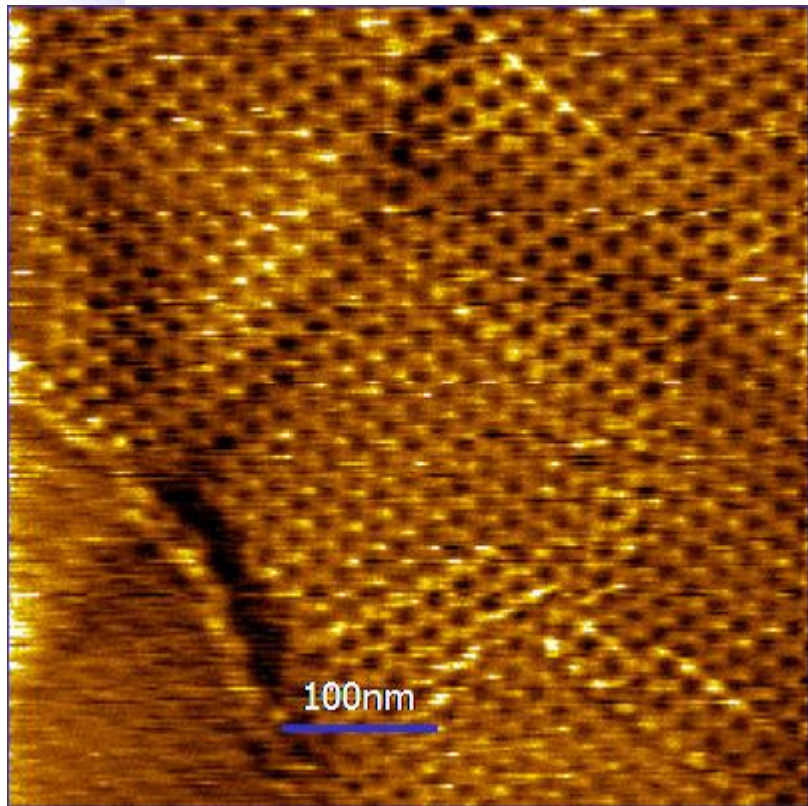

30T, drop casted from
0.58 μ M solution in THF after
slow evaporation

Epitaxial registry on graphite, Conformation?
Molecular modeling needed

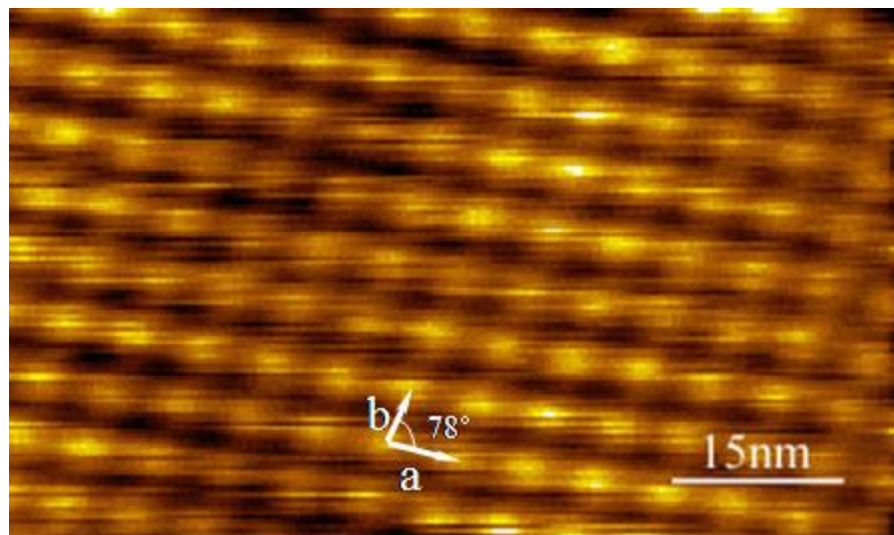

Self-assembled structure of TG2-12 on HOPG. STM topographic image.
The unit cell dimensions are $a=(6.4\pm 0.1)$ nm, $b=(5.4\pm 0.1)$ nm, $\alpha=(78\pm 2)^\circ$
Tunneling conditions for the STM image: $U_t=0.1$ V, set point current=1nA.



Self-Assembly of 14T-1 on HOPG

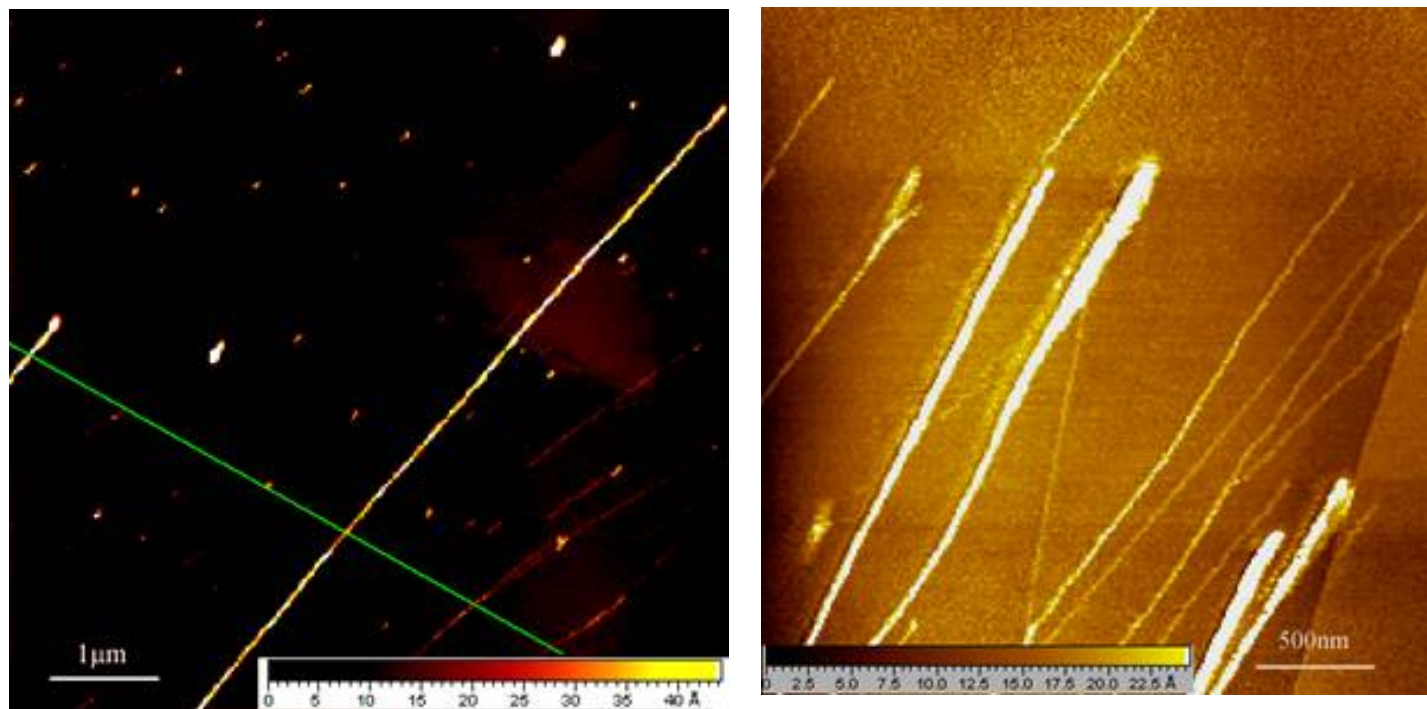

14T-1 on HOPG, films prepared from (a) 0.11 μM solution; (b) 1.1 μM solution. The solvent was allowed to evaporate very slowly.



Epitaxial Packing of 14T on HOPG

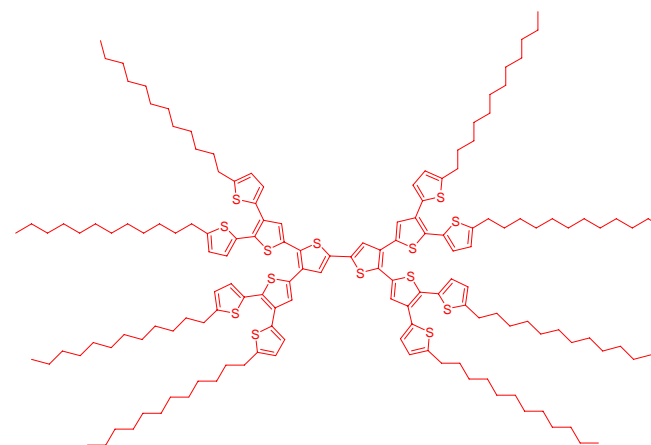
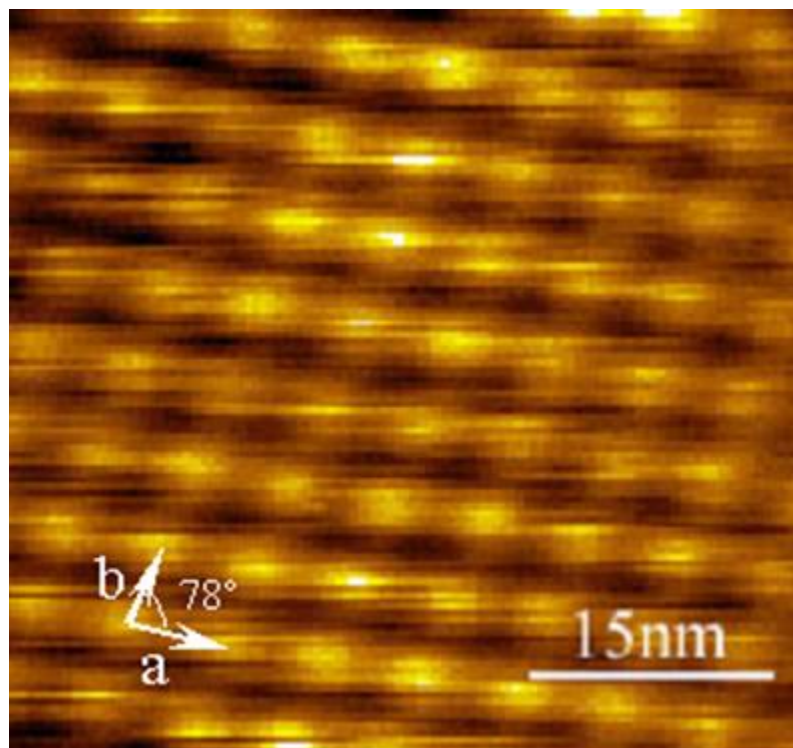

Self-assembled structure of 14T on HOPG. STM topographic image. The unit cell dimensions are $a=(6.4\pm 0.1)\text{nm}$, $b=(5.4\pm 0.1)\text{nm}$, $\alpha=(78\pm 2)^\circ$. Tunneling conditions for the STM image: $U_t=0.1\text{V}$, set point current= 1nA .

Xia, C.; Advincula, R.*; Locklin, J.; Giess, A.; Nonidez, W.
“Characterization, Supramolecular Assembly, and Nanostructures of Thiophene Dendrimers” *J. Am. Chem. Soc.* **2004**, *126*, 8735-8743.



Outline of Projects

- ▶ **Project 1.** Electrodeposition and Patterning of Conjugated Polymers Using The Precursor Polymer Approach.
- ▶ **Project 2.** Nanostructured Ultrathin Films of Oligothiophenes and Dyes.
- ▶ **Project 3.** Living Anionic Surface Initiated Polymerization (LASIP) on Nanoparticles
- ▶ **Project 4.** Nanoparticle Synthesis Using Block Copolymer Micelles, Star Copolymers and Polyelectrolyte Complexes
- ▶ **Project 5.** Functional Dendrimers as Organic Nanoparticles
- ▶ **Project 6.** Hybrid Nanoparticle-Dendron Materials: Energy Transfer Phenomena
- **Conclusions**



Project 6

Hybrid Nanoparticle-Dendron Materials:
Energy Transfer Phenomena

Welch Foundation



CdSe Nanoparticles



Fluorescence efficiency and stability is strongly affected by capping agent

- Spatial confinement of electronic excitation to physical dimensions of the nanocrystals (particle in a box)

- Strong absorbers ($\epsilon = 36,000 - 700,000$) depending on size

- High surface/volume ratio nanoparticles

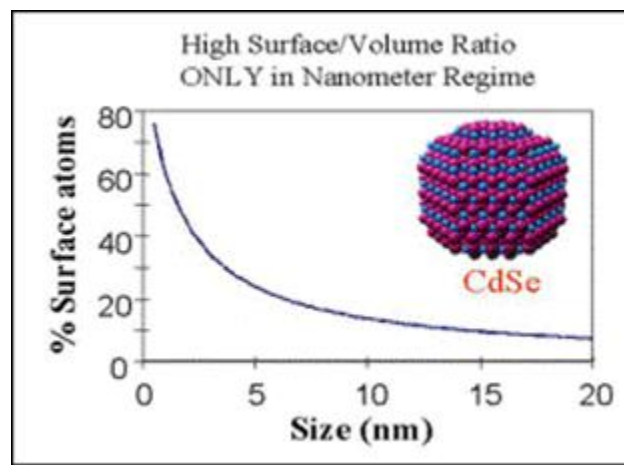



Ligands for Semiconducting Nanocrystals

The nature of the capping agent can have a *profound effect* on the photophysics of the nanoparticles

- Organic and inorganic capping agents have been employed
- Organic ligands offer improved solubility in common organic solvents

Some Typical Organic Ligands

- Phosphine/Phosphine Oxide, e.g. trioctylphosphine/trioctyl phosphine oxide
- Alkylamine, e.g. octadecylamine
- **Dendrimers**, e.g. poly(amidoamine)
- **Electroactive surfactants**, e.g. oligothiophenes, perylene based stabilizers

Some Typical Inorganic Shells

- Higher band gap materials, e.g. ZnSe
- Using this approach, fluorescence quantum yield has been increased by more than 50%

Core-shell Structure

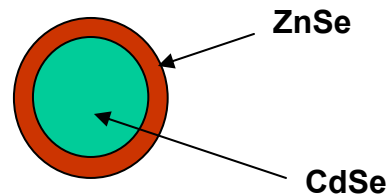



Gold Nanoparticles

- Potential applications in optoelectronics, electronics, catalyst, biosensors, etc.

Surface Functionalization of Au NPs

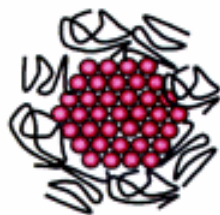

(a) polymer coated metal nanoparticles

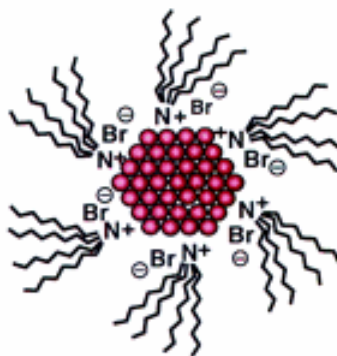

(b) TOAB capped metal nanoparticle

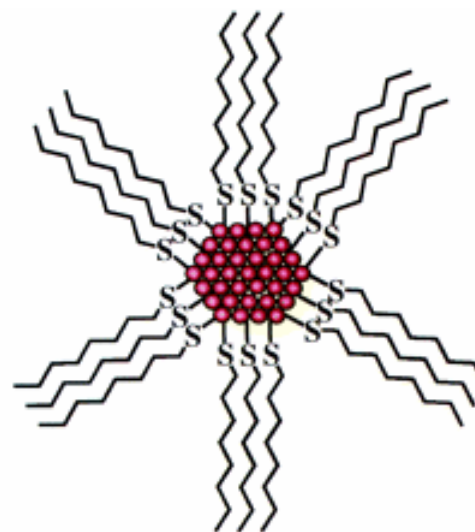

(c) alkyl thiol capped metal nanoparticle



Organic-inorganic Hybrid Nanostructures: Advantages and Applications

- From the strong interaction between metal nanoparticles and conjugated polymers, unique photophysical and electrochemical properties are expected to arise leading to a wide range of potential applications in electronic and optoelectric devices

Electroluminescence Enhancement With Polyfluorene/Au NP nanocomposites

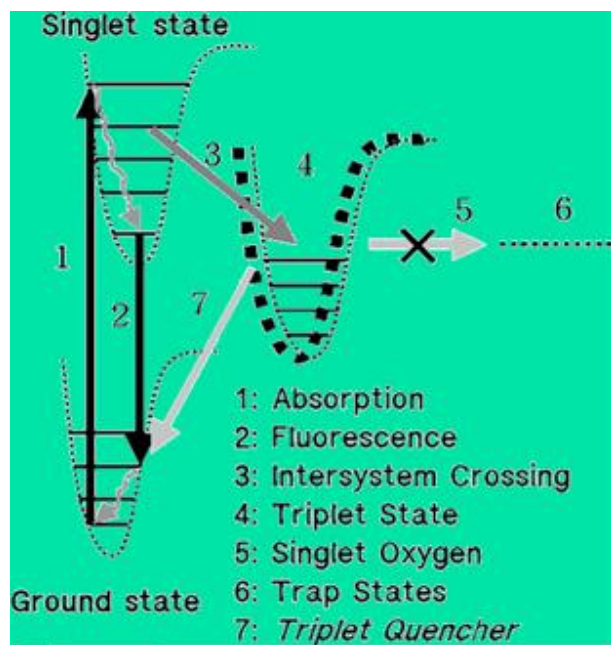

Chem. Mater. **2004**, 16, 688.

Recognition and Detection of Biomolecules

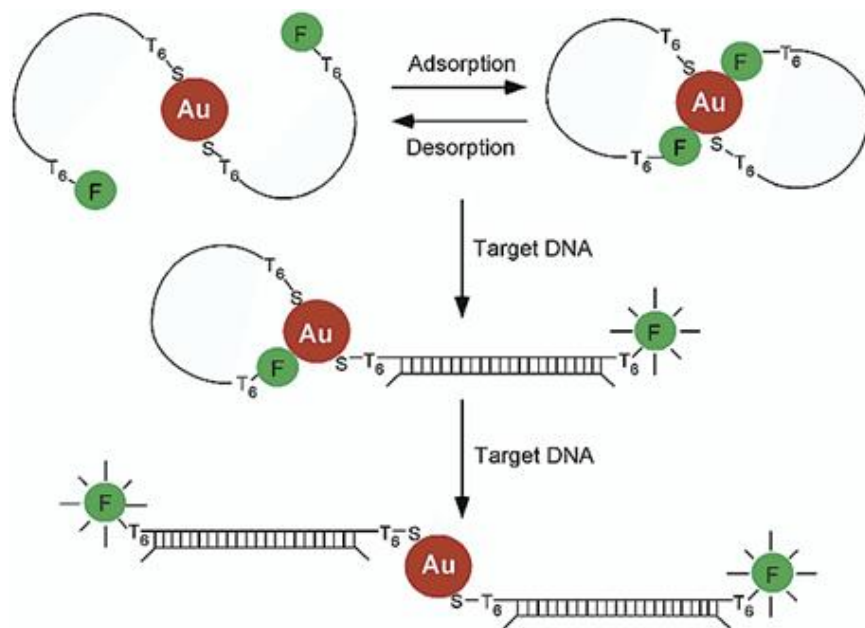

JACS **2002**, 124, 9606.



Project 6a. Dendron Stabilized Quantum Dot Nanoparticles

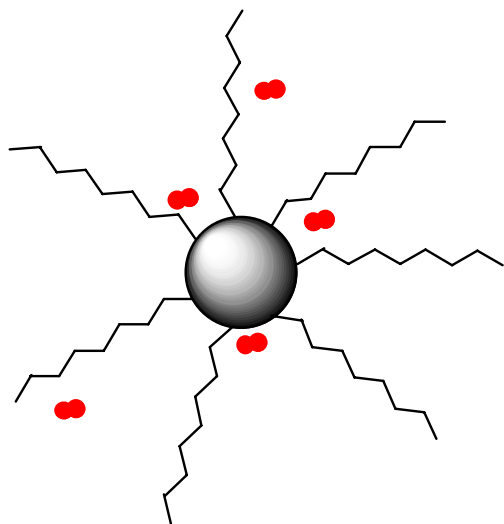

Linear- TOPO capped

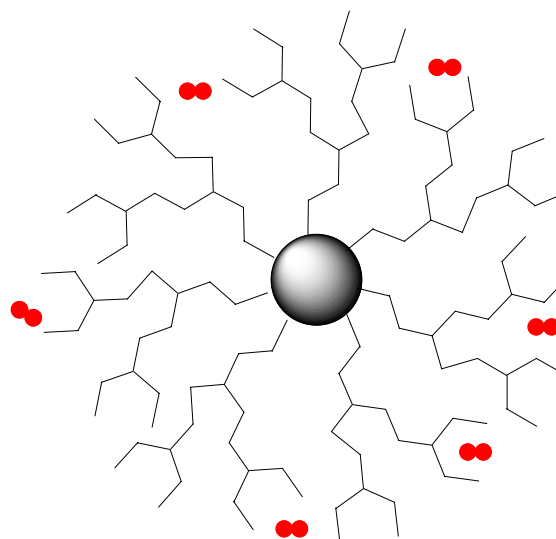

Hyperbranched- Dendron capped

Advantages of dendron capping:

- Increased thermal, chemical, and photochemical stability
- More reliable workup (processing) procedures

Wang et al. *JACS* 2002, 124, 2293

Guo et al. *JACS* 2003, 125, 3901



Synthesis and Spectroscopic Properties of Branched P7T

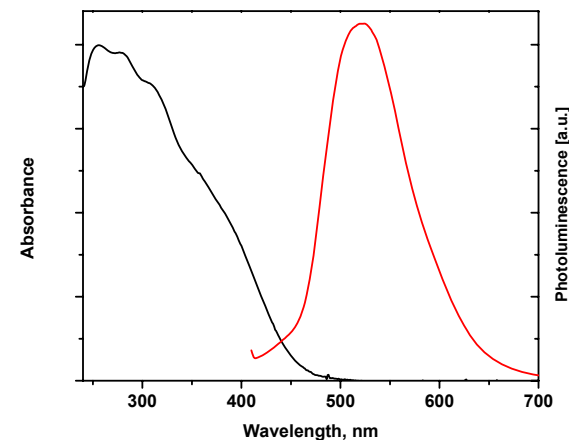
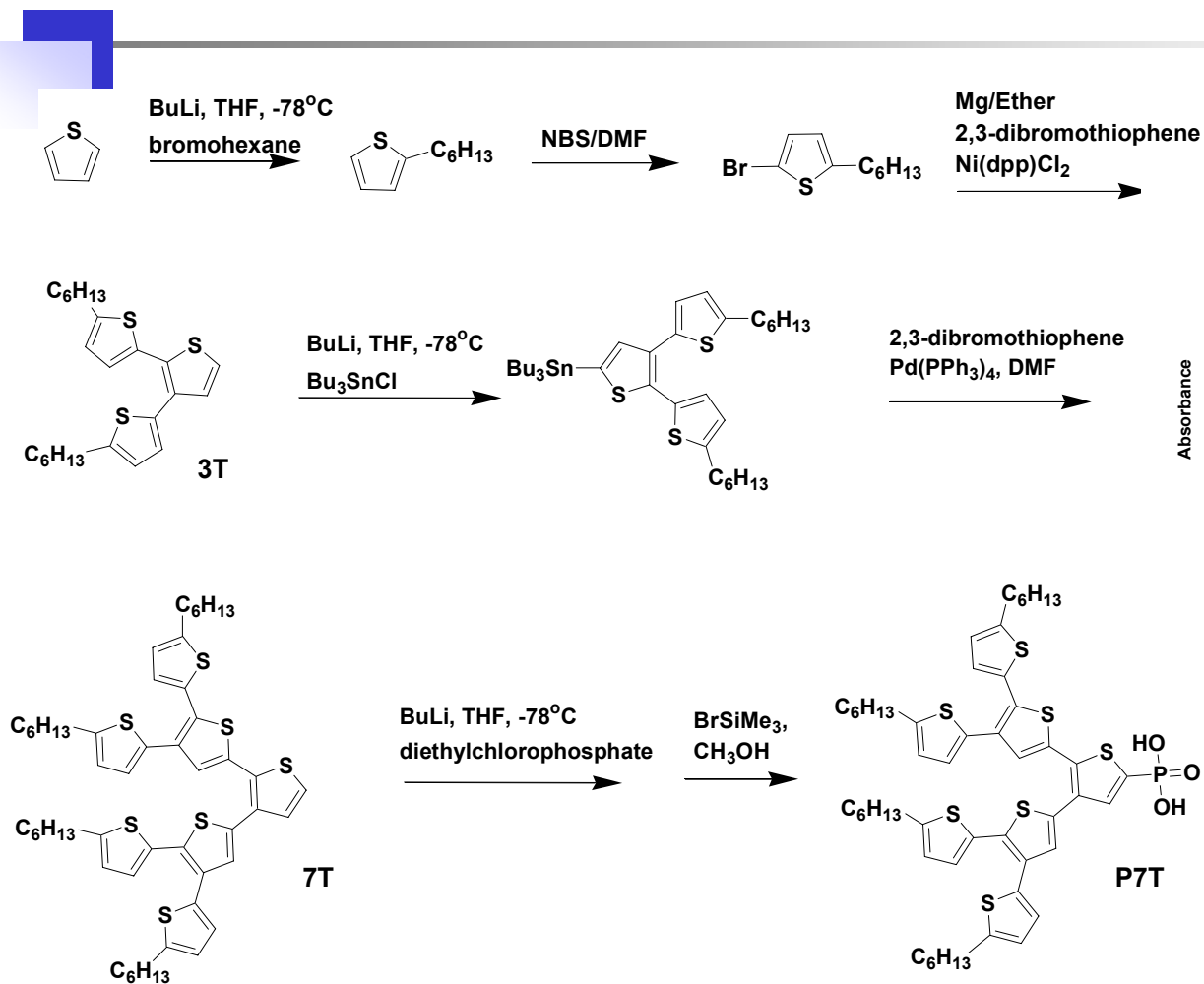

QY = 25 %
 $\epsilon = 23,301$
 $E_g = 2.66$ eV

Broad Absorbance Spectrum
Emission $\lambda_{\max} = 521$ nm

P7T Ligand Exchange

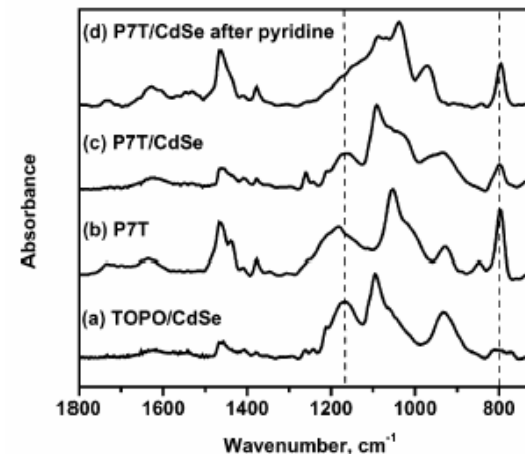
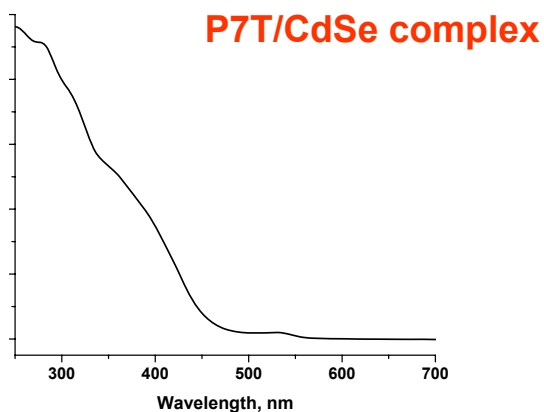
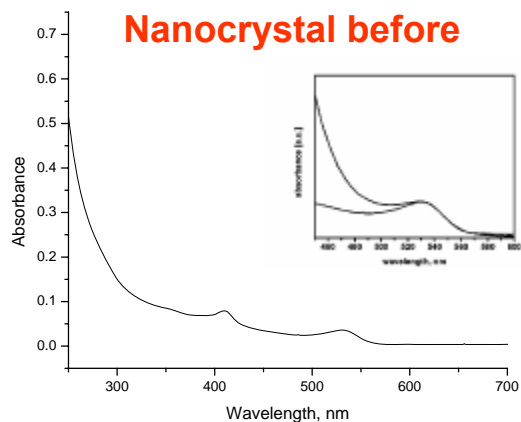
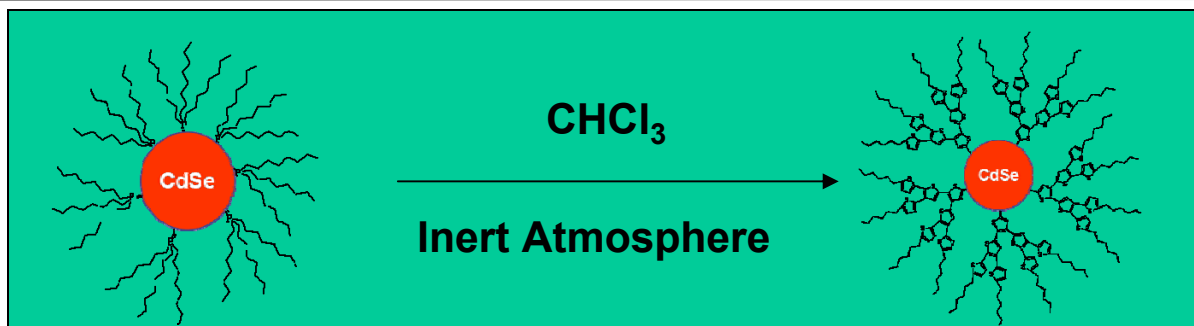

- Deconvolution: ~30 dendrons per nanocrystal
- FT-IR can use to follow changes on the P=O stretching region. Peak at 796 cm^{-1} imp.
- Photoluminescence of nanocrystal and dendron are quenched: electron transfer between ligand and nanoparticle
- Synthesis of TOPO-capped CdSe using Peng et. al. procedure *J. Am. Chem. Soc.* **2001**, 123, 183.



Photovoltaic Cells: Hybrid Materials

- Nanocrystals are good electron acceptors
- Nanocrystal visible band gap, both conjugated polymer and nanocrystal contribute to absorption

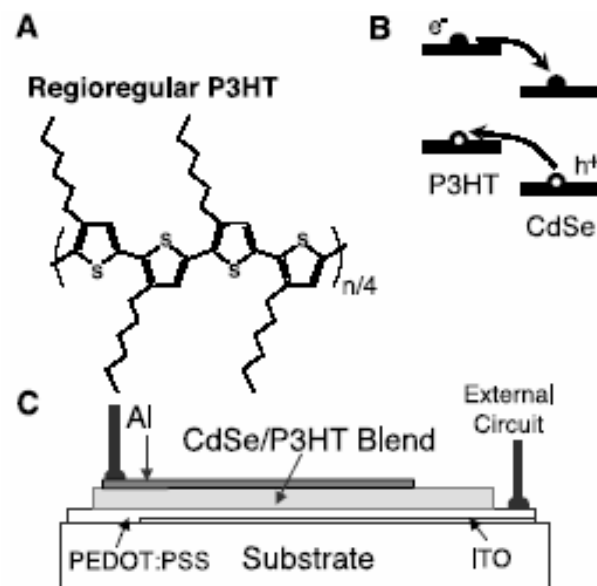
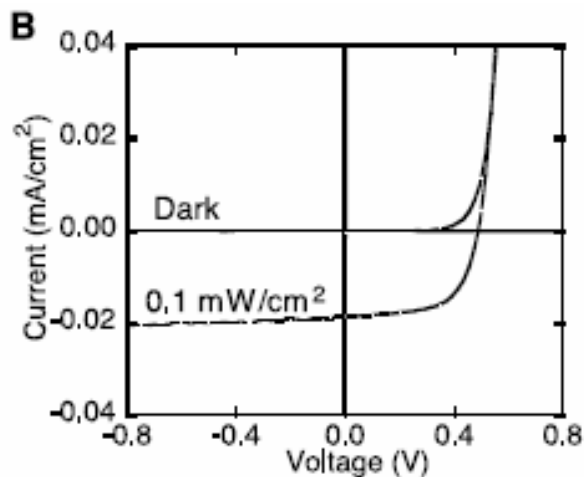

PREVIOUS:
Major factor with CdSe photovoltaic cells is the aggregation (phase separation) of CdSe nanocrystals within conjugated polymer matrix.



Hybrid Material: Current-Voltage Response of Film

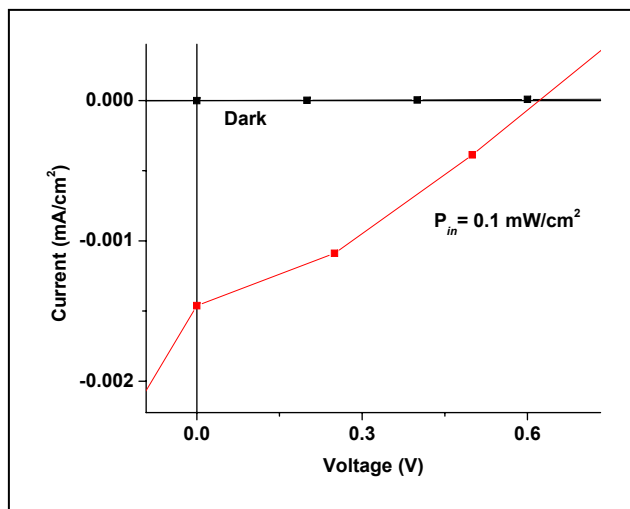
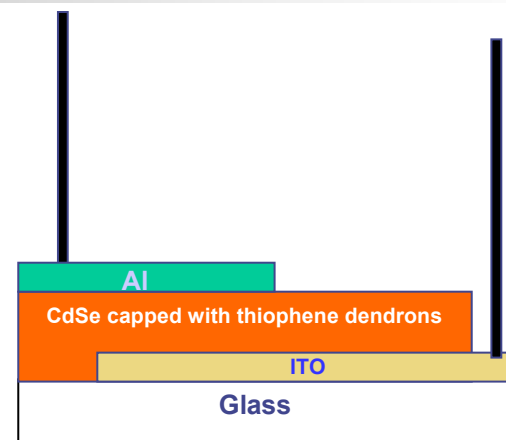
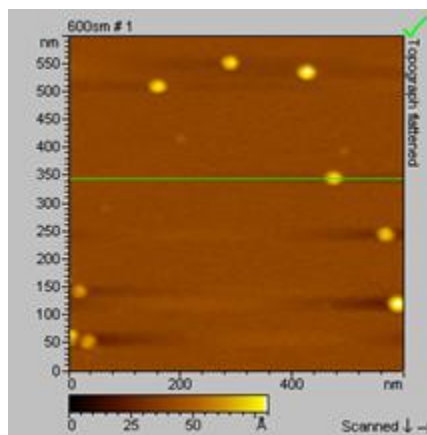
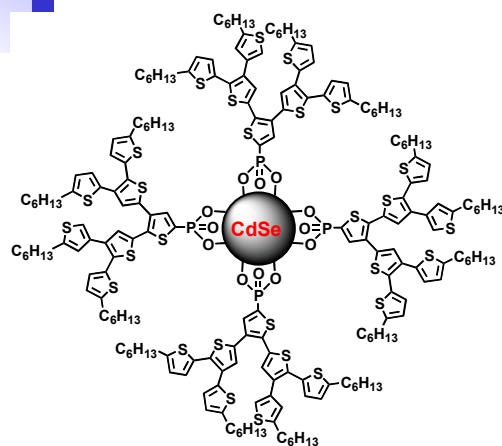

$$\begin{aligned}V_{oc} &= 0.62 \text{ V} \\I_{sc} &= 1.56 \times 10^{-6} \text{ A/cm}^2 \\FF &= 0.3 \\P_{in} &= 0.1 \text{ mW/cm}^2\end{aligned}$$

Power Conversion Efficiency, $\eta_e = 0.29 \%$

Device Fabrication. The P7T/nanocrystals were spin-cast onto indium tin oxide (ITO)-coated glass substrates (cleaned by the RCA method)¹⁹ at 1200 rpm for 60 s. The thickness of the layer was ~50–80 nm (as determined by AFM profilometry). Aluminum (100 nm) was evaporated on the active layer at a rate of 0.5–1.0 Å/s. The active area of the device was 0.23 cm². The current–voltage characteristics were measured using a Keithley 236 source measure unit with a Oriel Hg–Xe lamp hooked up to a monochromator. At least 10 devices were tested, and the values given below are an average of all working devices. The incident power (P_{in}) was 0.14 mW/cm². The power conversion efficiency (η_e) was calculated according to the following equation:

$$\eta_e = I_{sc} V_{oc} (FF) / I_{in}$$

where I_{sc} is the short-circuit current density (mA/cm²), V_{oc} is the open-circuit voltage, I_{in} is the intensity of irradiating light (mW/cm²), and FF (fill factor) is defined as

$$FF = \max\{IV\} / I_{sc} V_{oc}$$



Energy Transfer in Gold Nanoparticles Capped with α -Functionalized Thiophene Dendrons



Previous Project: Functionalization of PAMAM Dendrimer

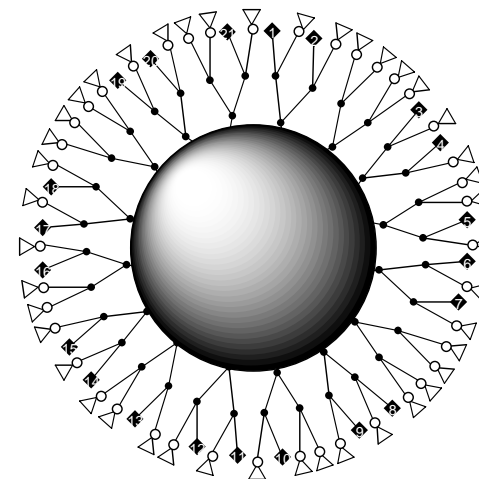
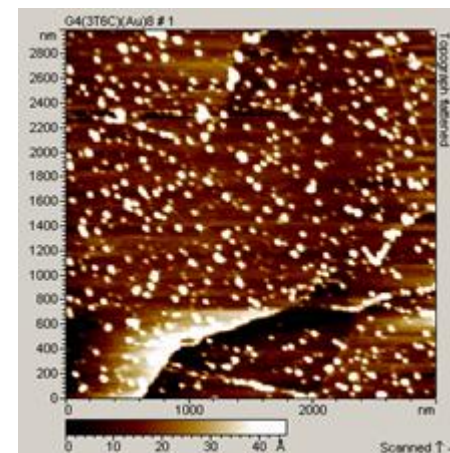
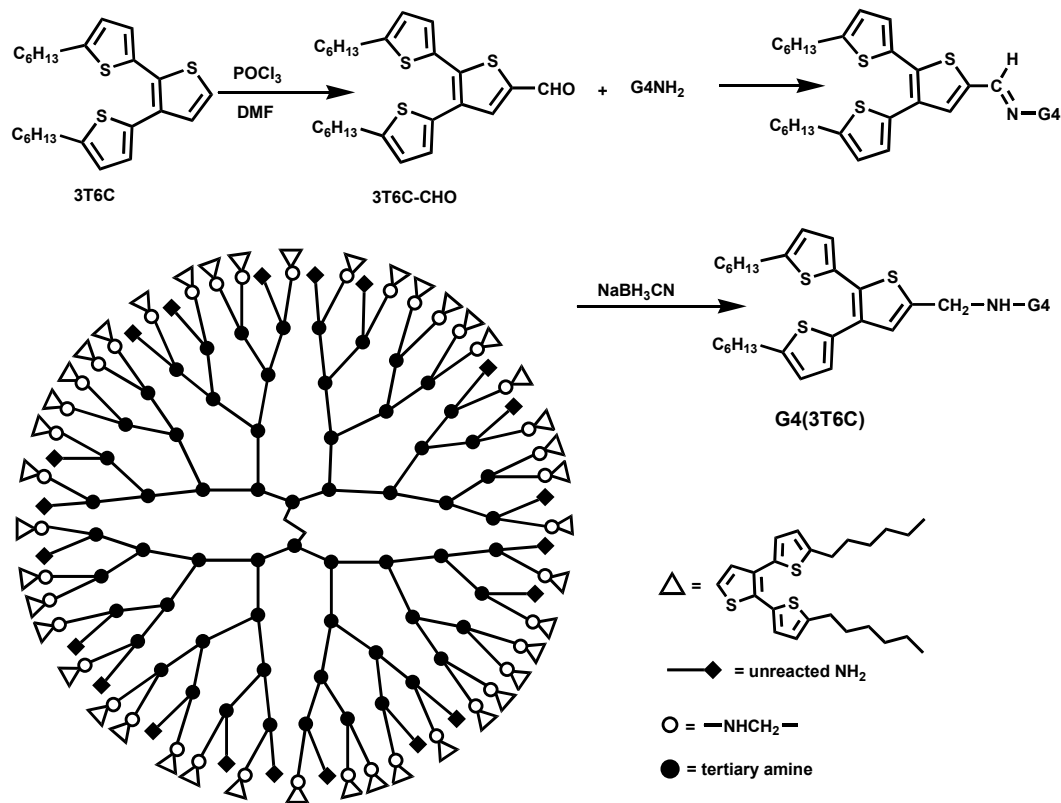

Deng, S.; Advincula, R. C. et.al. *J. Am. Chem. Soc.* **2005**, 127, 1744

Metal Nanoparticle in Dendrimer



Ligand Design

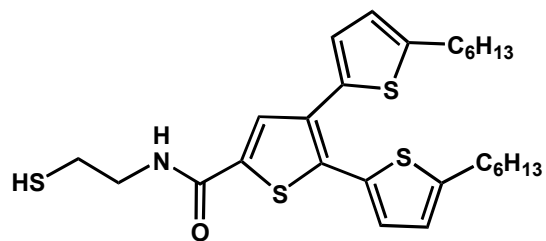

HSC₂3T6C

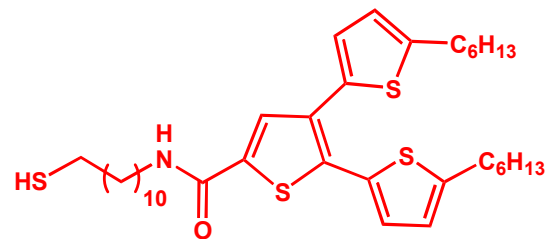

HSC₁₁3T6C

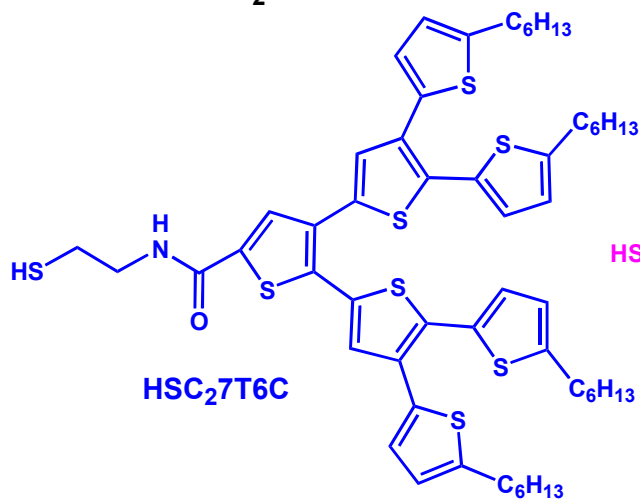

HSC₂7T6C

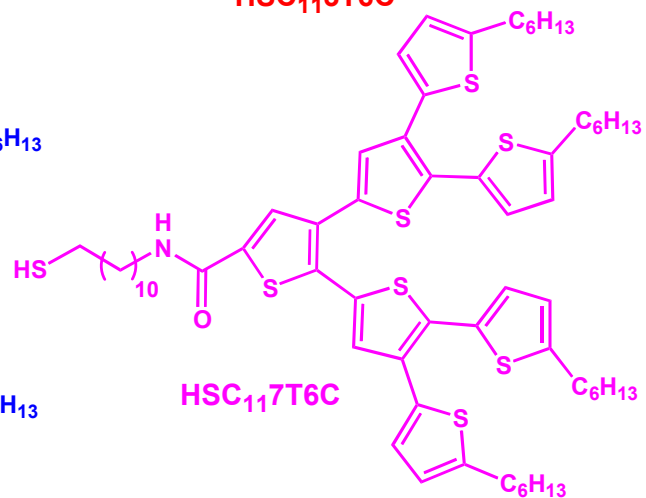

HSC₁₁7T6C



Ligand Synthesis: 3T and 7T

3T and 7T Chain Length Variation

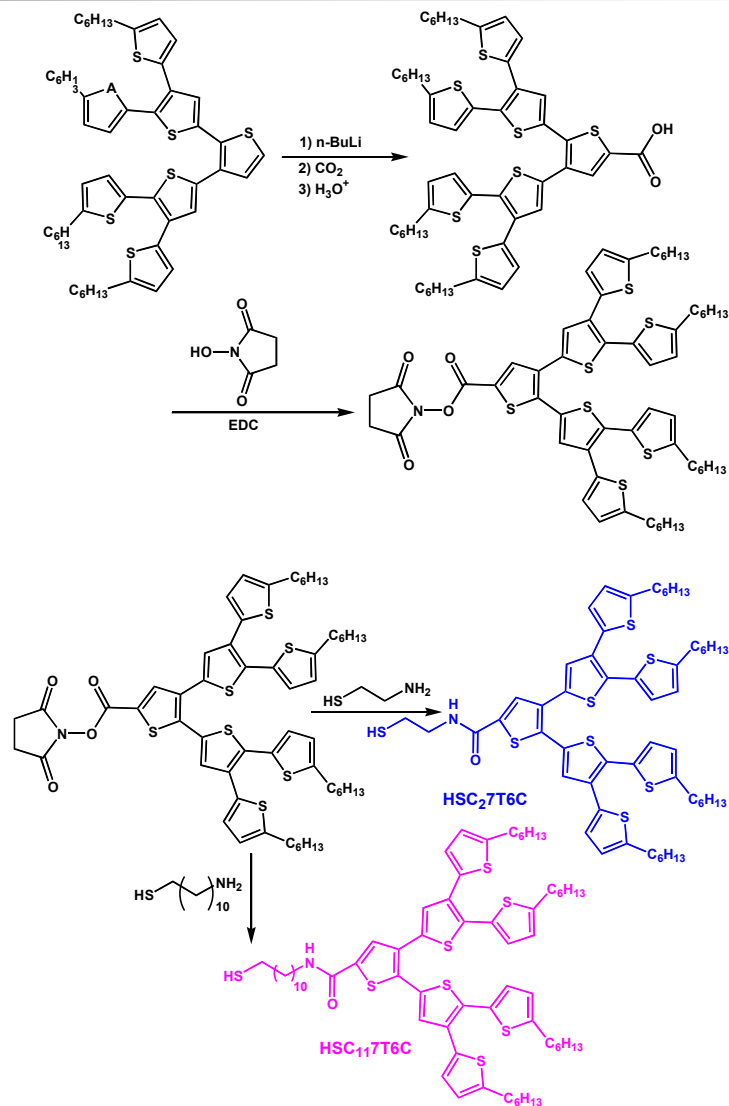
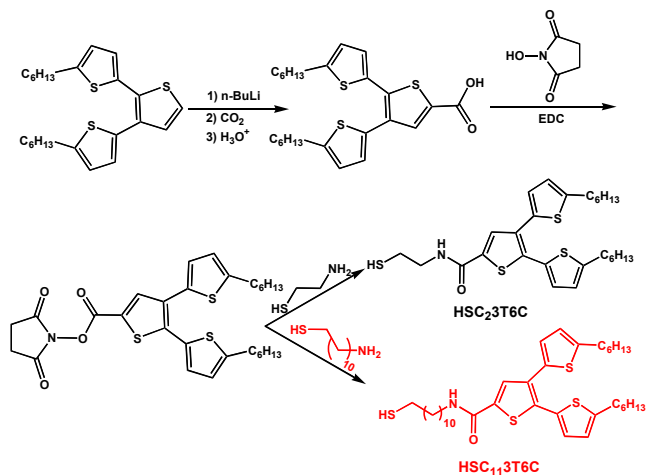



Au NPs Synthesis and hybridization

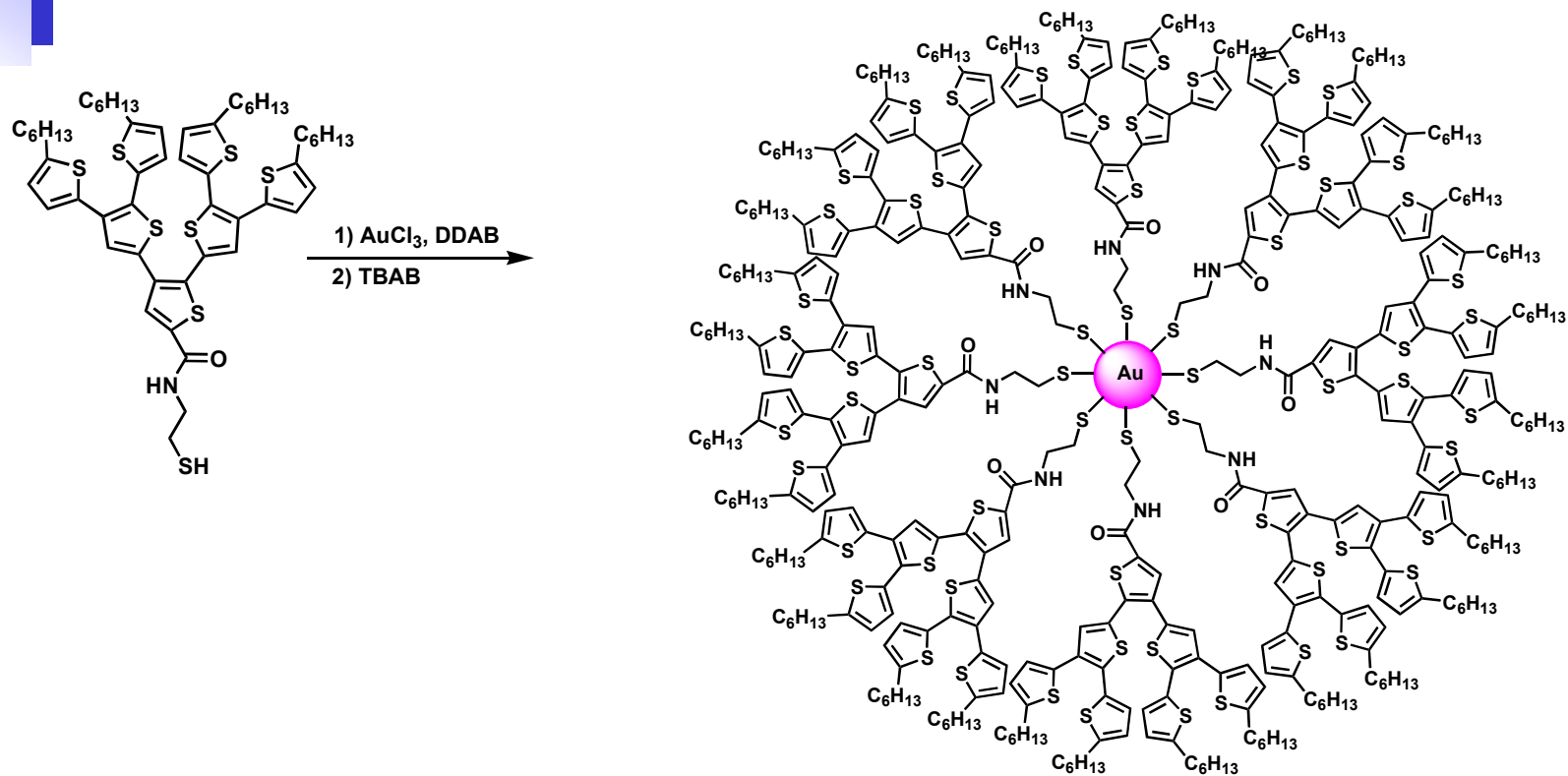



NMR and IR Comparison

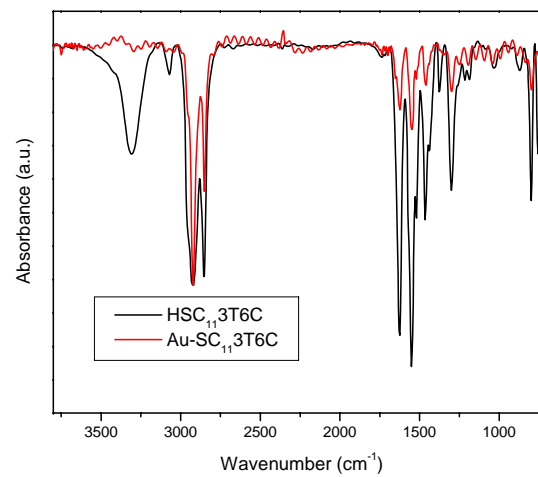
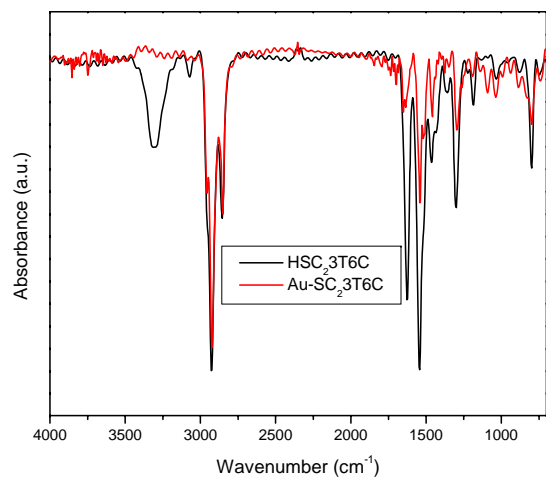
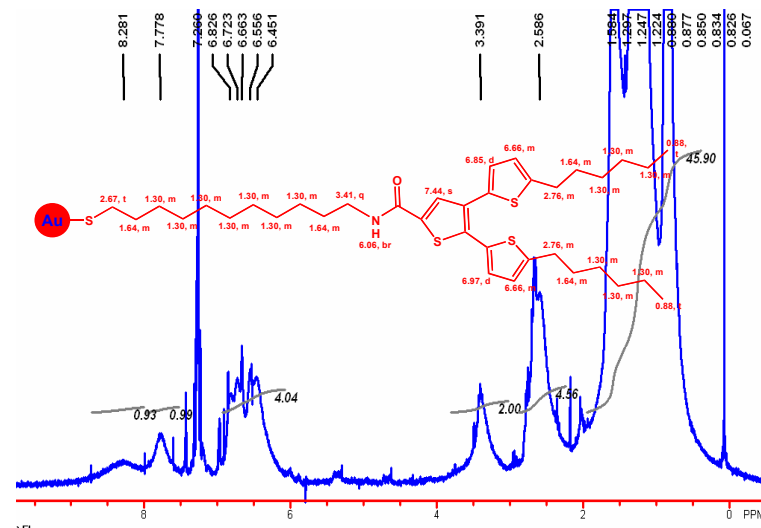
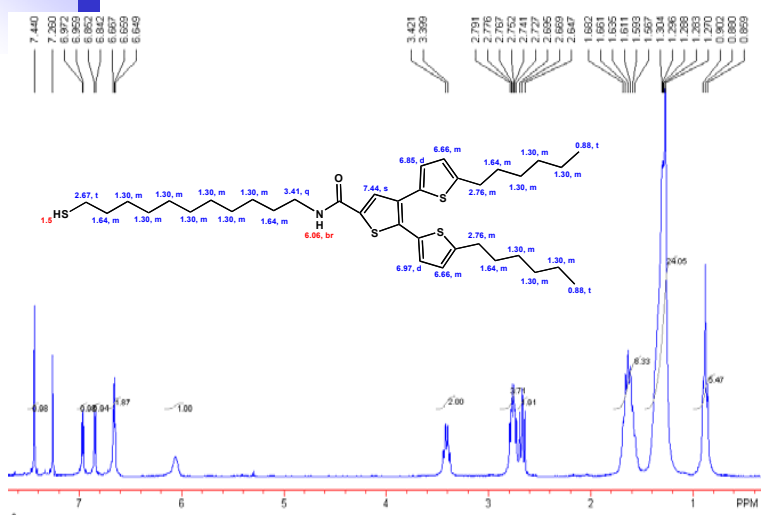



UV-vis Spectra: Effects of Different Chain Lengths for 3T

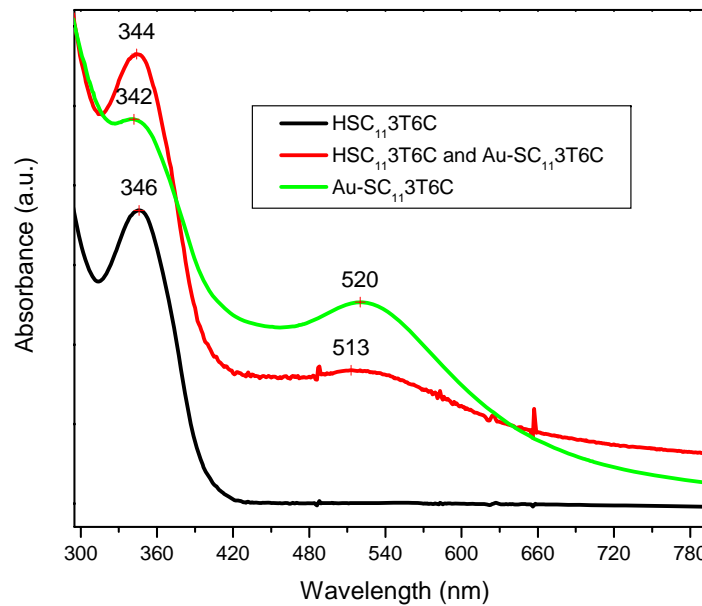
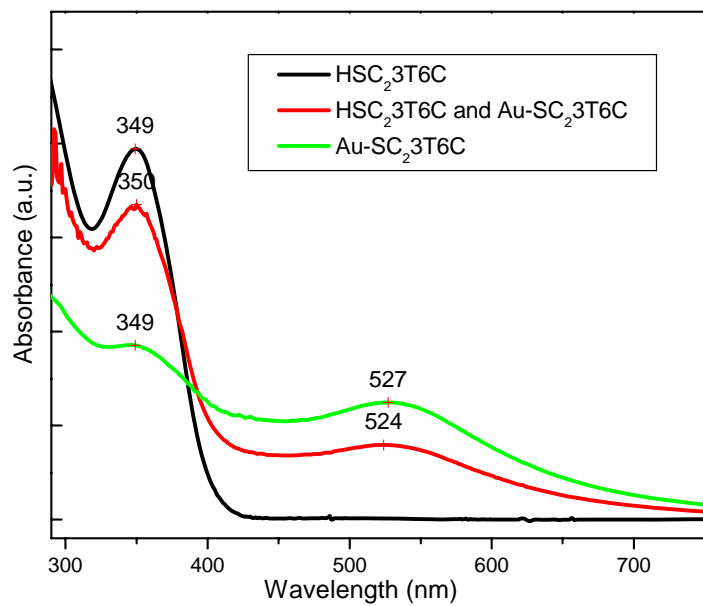



UV-vis Spectra: Effects of Different Chain Lengths for 7T

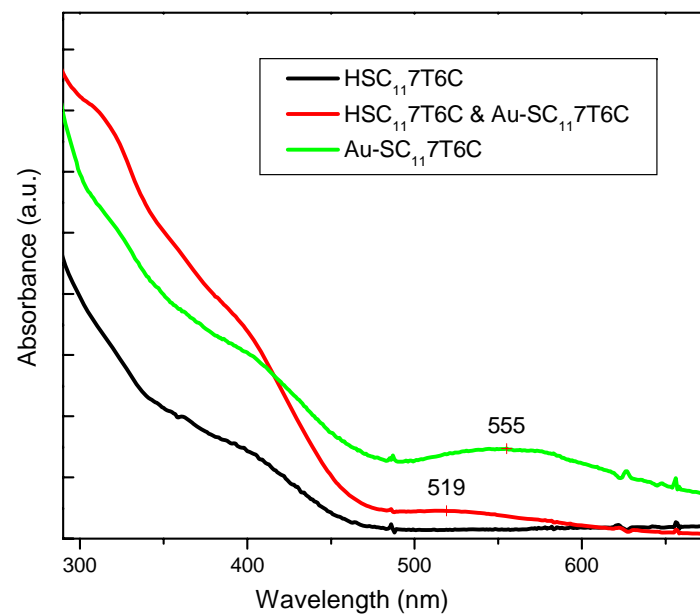
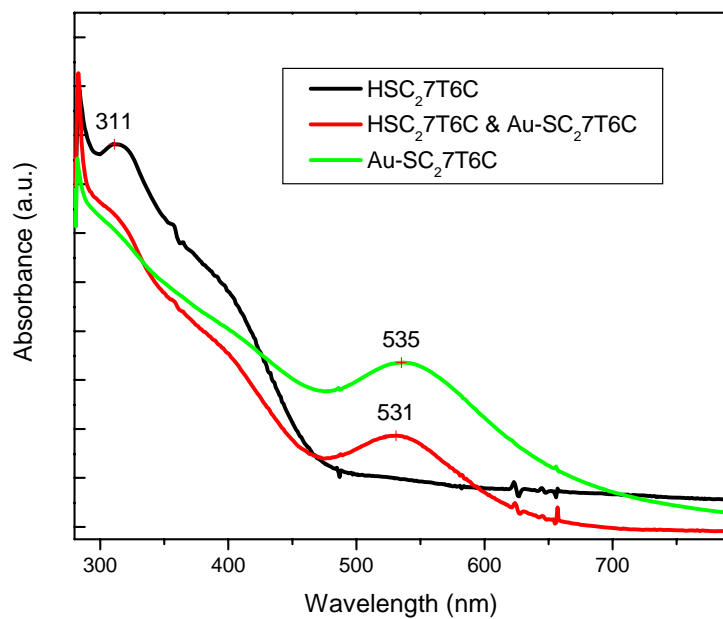



MPCs vs. Optically Matched Mixtures

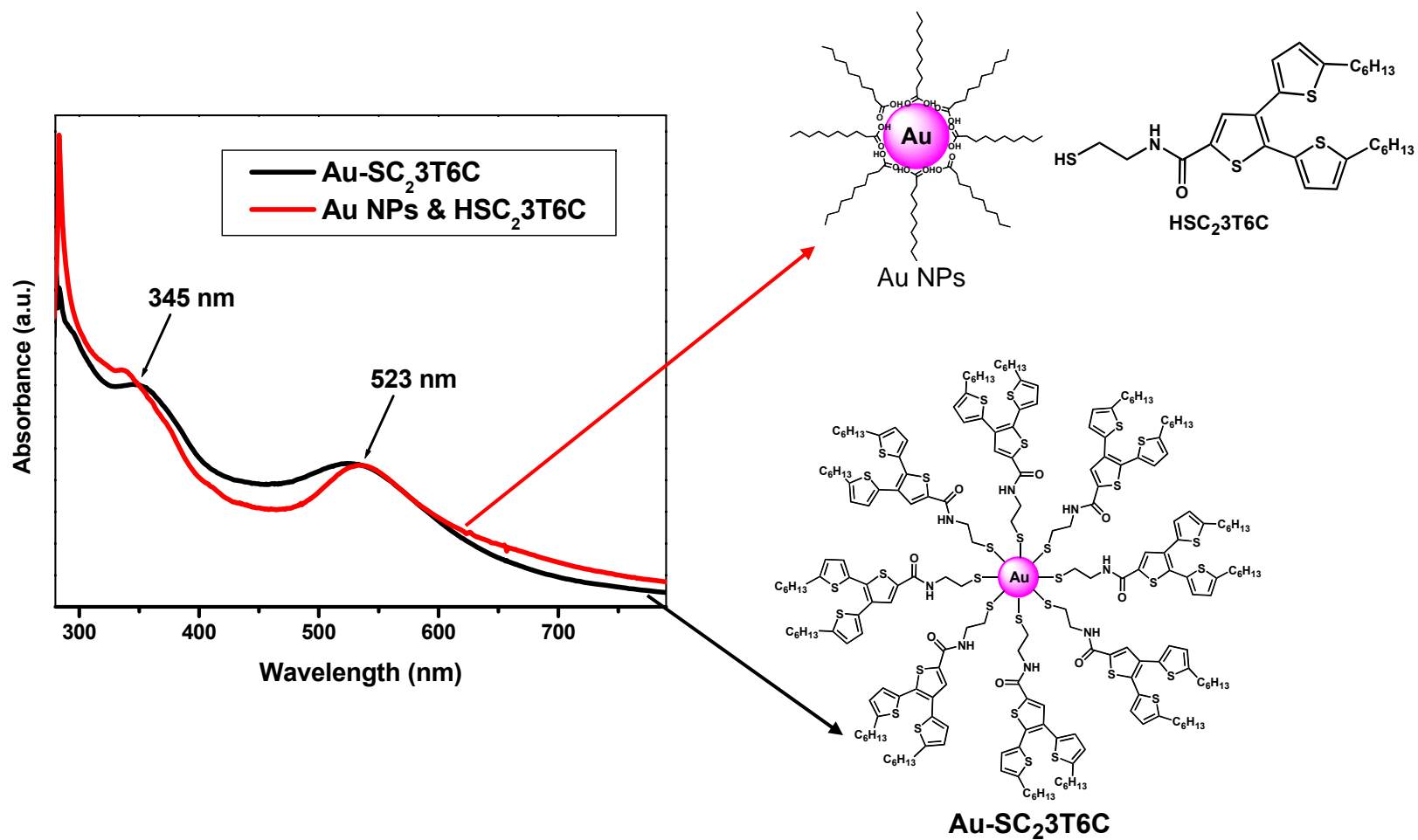



Energy Transfer Studies

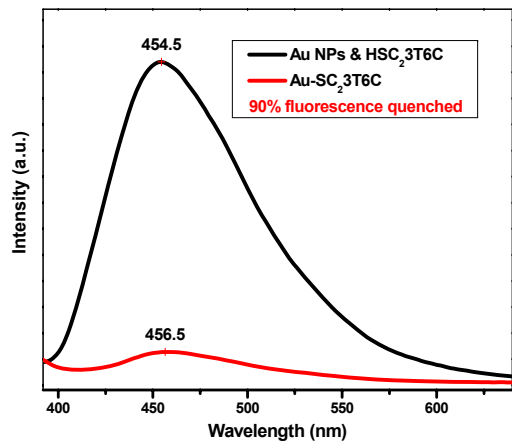

3T

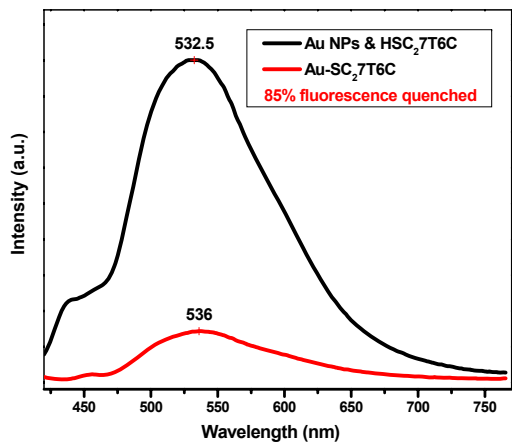
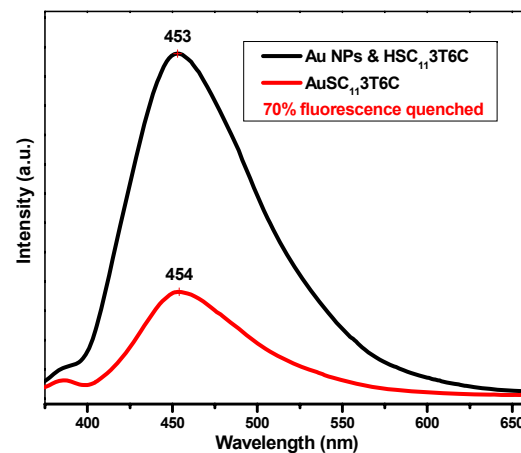

7T

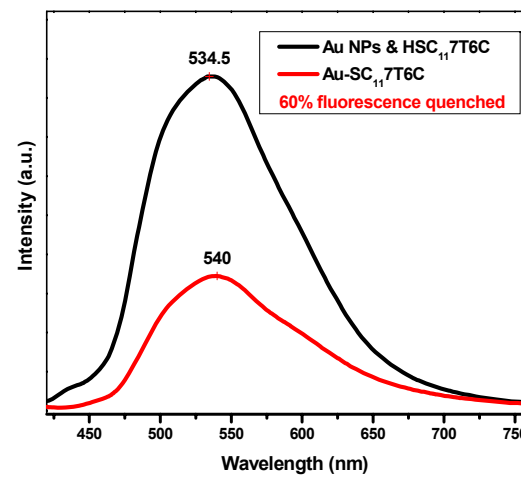



Conclusions

- Nanostructured Materials are important for improved properties and phenomena
- Nanotechnology owes both to organic and inorganic/metal materials and hybrids.
- **Organic and Polymer Synthesis is essential to nanotechnology!**
- Nanoscale phenomena is observed in a variety of sizes, geometry, and shapes: ultrathin films to nanoparticles
- An interdisciplinary approach is critical for future growth in this field.